

MotorGuide REPAIR PARTS

Model:
ZX60HVB

SPECIFICATIONS:

Year of Intro 1998
 Thrust 67LBS
 Volts 24VDC
 Amp Draw 0 to 33 amps
 Mount 20 Bow
 Speeds Variable

QUICK REFERENCE PARTS GUIDE:

Foot Box Switch FP149-01
 MOSFET JF096-07
 DA Board JF157-02
 FOR/REV Switch FP153-06

PARTS ORDERING & TECH ASSISTANCE

MotorGuide Consumer Relations
 Phone 918-831-6989
 Fax 800-982-8093

Send Returned Goods to:
 MotorGuide
 605 Hwy 12 West
 Starkville, MS 39760

Returned Goods must be accompanied with a Returned Goods Authorization. Contact MotorGuide Consumer Relations to obtain RGA.

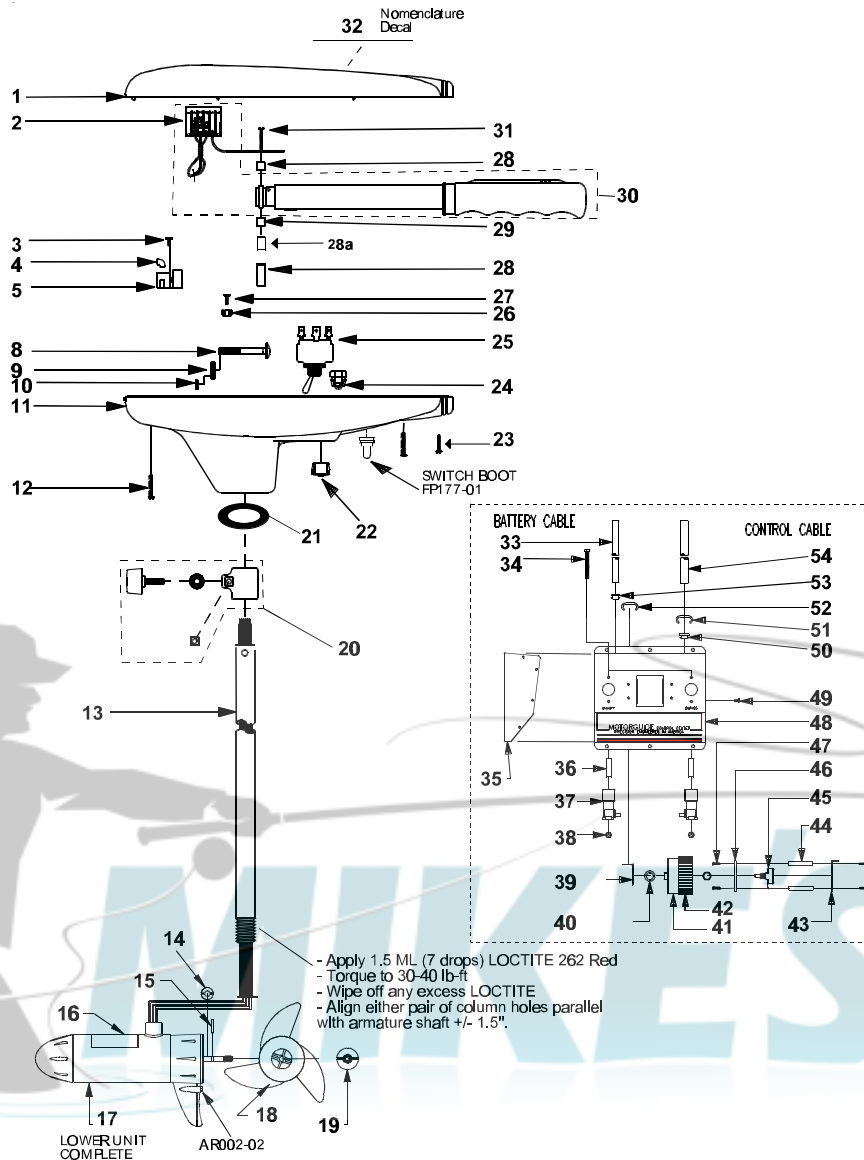

KEY	DESCRIPTION	PART #	KEY	DESCRIPTION	PART #
1	T/H COVER COMPLETE BLACK	AT053-18	26	DEPTH ADJUSTMENT COLLAR	AR051-01
2	AMP CONNECTOR	AP029-01	27	HOLE PLUG	FP021-03
3	NOT APPLICABLE		28	GROMMET	GR019-03
4	NOT APPLICABLE		29	FWD/REV SWITCH 2 POSITIONS	FP153-06
5	SELF TAPPING SCREW	AF141-01	30	TERMINAL BLOCK	FT160-01
6	INSULATING SLEEVE	AT080-01	31	#10 X 1/2" SCREW	GR133-01
7	DURA AMP BOARD	JF157-02	32	WIRE BRACKET	AT155-04
8	#10 X 1/2" SCREW	GR133-01	33	RETAINER	AR036-01
9	TERMINAL BLOCK	FT160-01	34	HANDLE ASY	AR372-10
10	BOLT	TT134-01	34	8 X 1-3/8 SCREW	AR133-01
11	CURVED WASHER	TT171-04	35	RETAINER	AR036-01
12	NYLON LOCK NUT	XT098-02	36	SCREW	AR133-01
13	T/H BASE BLACK	AR004-14	37	NOMENCLATURE	FR056-11
14	SCREW #8 X 1"	LF141-04	38	BATTERY CABLE	FP328-03
15	BAR KNOB DEPTH ADJUSTMENT	AR082-02	39	FOOT SWITCH COVER	FP353-03
16	COLUMN CLAMP WASHER	AR171-01	40	FOOT SWITCH	FP149-01
17	COLUMN SUPPORT NUT	FR098-01	41	ROTARY KNOB	AP082-02
18	COLUMN 42"	FR049-15	42	POTENTIOMETER	AP168-02
	COLUMN 50"	FR049-13	43	CONTROL CABLE	FP327-04
19	LOWER UNIT DECAL	ET060-04	44	NOT APPLICABLE	
20	MONOFILAMENT WASHER	AR175-01	45	FOOT BOX ASY COMPLETE	PP300-02
21	PROP DRIVE PIN	BR102-01	46	COLUMN SEAL	AT079-01
22	PROP/2 BLADE	AF124-07			
23	PROP NUT	AR099-01			
24	H/O MOTOR	UF397-01			
25	DEPTH COLLAR ASY	AR158-01			

LOWER UNIT BREAKDOWN

Model:
ZX60HVB

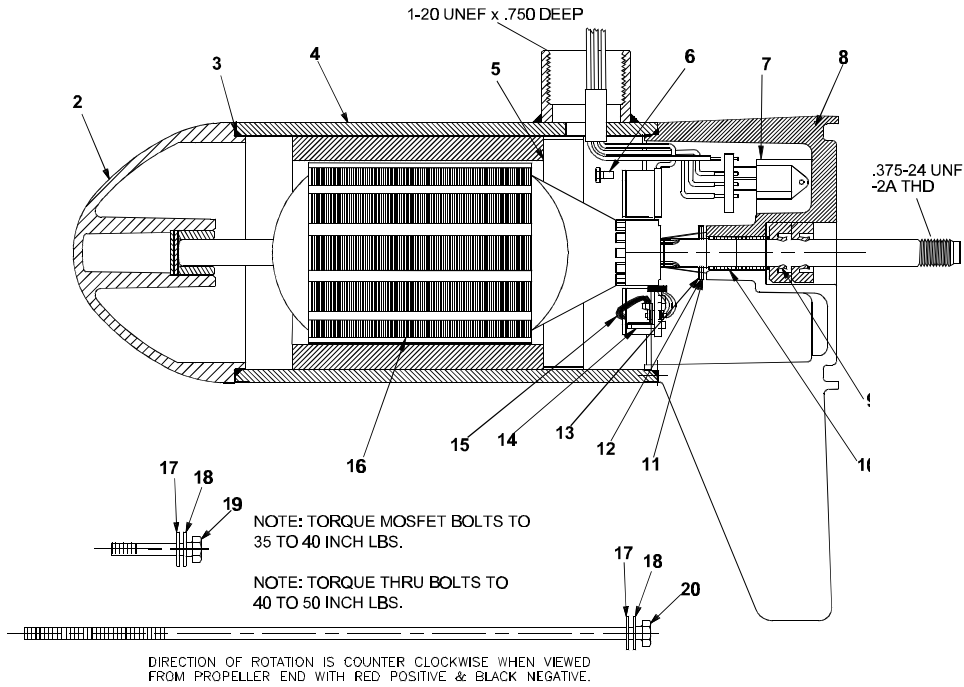

WIRING

12V & 24V D.A. WIRING DIAGRAM

