

MotorGuide® REPAIR PARTS

Model:
ZX55HB

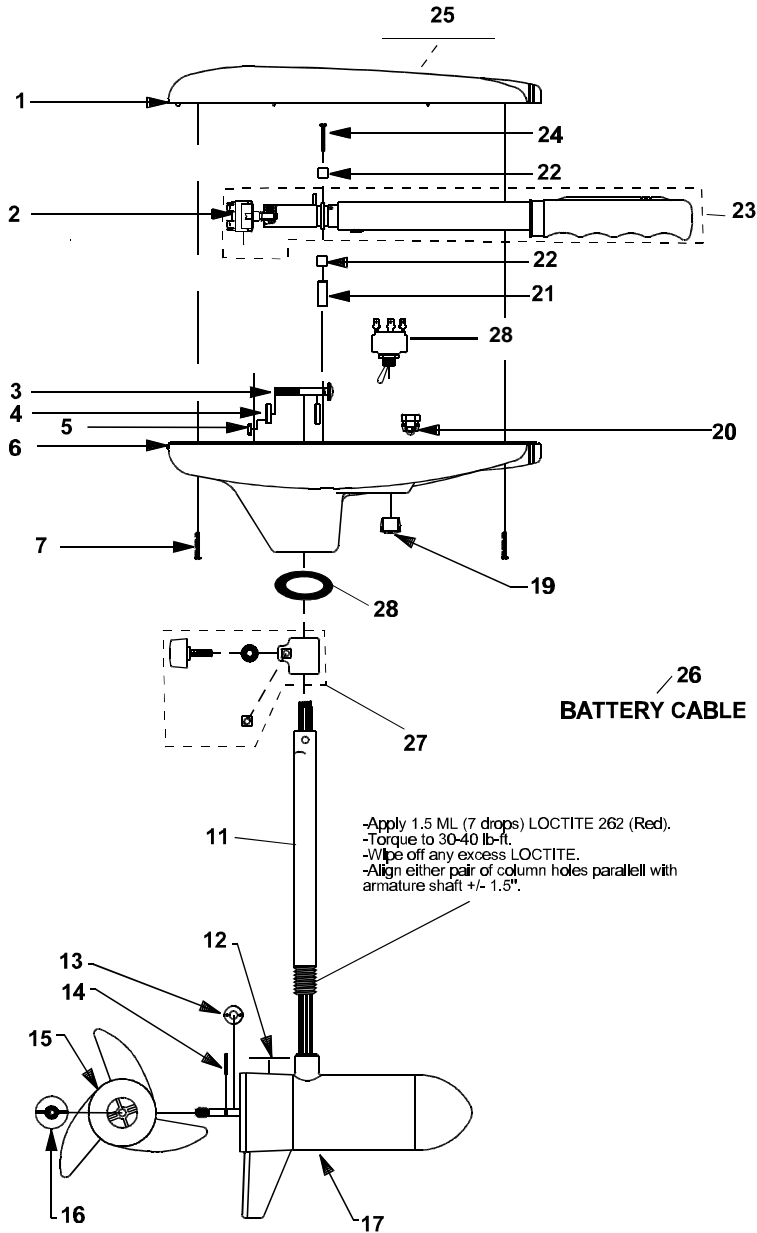

SPECIFICATIONS:

Year of Intro	1998
Thrust	56LBS
Volts	12/24VDC
Amp Draw	0 to 34 amps
Mount	15 or 20
Speeds	5 For/Rev

QUICK REFERENCE PARTS GUIDE:

Handle Asy	BT372-06
Motor Seal Kit	6220
Rotary Switch	KT150-02

PARTS ORDERING & TECH ASSISTANCE

MotorGuide Consumer Relations
Phone 918-831-6989
Fax 800-982-8093

Send Returned Goods to:

MotorGuide
605 Hwy 12 West
Starkville, MS 39760

Returned Goods must be accompanied with a Returned Goods Authorization. Contact MotorGuide Consumer Relations to obtain RGA.

KEY	DESCRIPTION	PART #	KEY	DESCRIPTION	PART #
1	COVER BLACK	AT053-16	27	DEPTH COLLAR ASY	AR158-01
2	ROTARY SWITCH	KT150-02	28	TOGGLE SWITCH	FP153-04
3	BOLT	TT134-01			
4	CURVED WASHER	TT171-04			
5	NYLON LOCK NUT	XT098-02			
6	T/H BASE BLACK	AR004-14			
7	SCREW #8 X 1"	LF141-04			
8	BAR KNOB	AR082-02			
9	CLAMP WASHER	AR171-01			
10	SUPPORT NUT	FR098-01			
11	42" .095 SS H/O COLUMN	FR049-15			
12	MARINE LOWER UNIT DECAL	AF060-04			
13	MONOFILAMENT WASHER	AR175-01			
14	PROP DRIVE PIN	BR102-01			
15	PROP/ 3 BLADE	AF124-10			
16	PROP NUT	AR099-01			
17	5 SP MOTOR	BF397-03			
18	DEPTH ADJUSTMENT COLLAR	AR051-01			
19	1/2" HOLE PLUG	FP021-03			
20	GROMMET	GR019-03			
21	WIRE BRACKET	AT155-04			
22	RETAINER CLAMP	AR036-01			
23	5 SPEED HANDLE ASY 96-97	BT372-06			
24	8 X 1-3/8 SCREW	AR133-01			
25	NOMENCLATURE	AT056-14			
26	BATTERY CABLE	AT328-06			

LOWER UNIT BREAKDOWN

Model:
ZX55HB

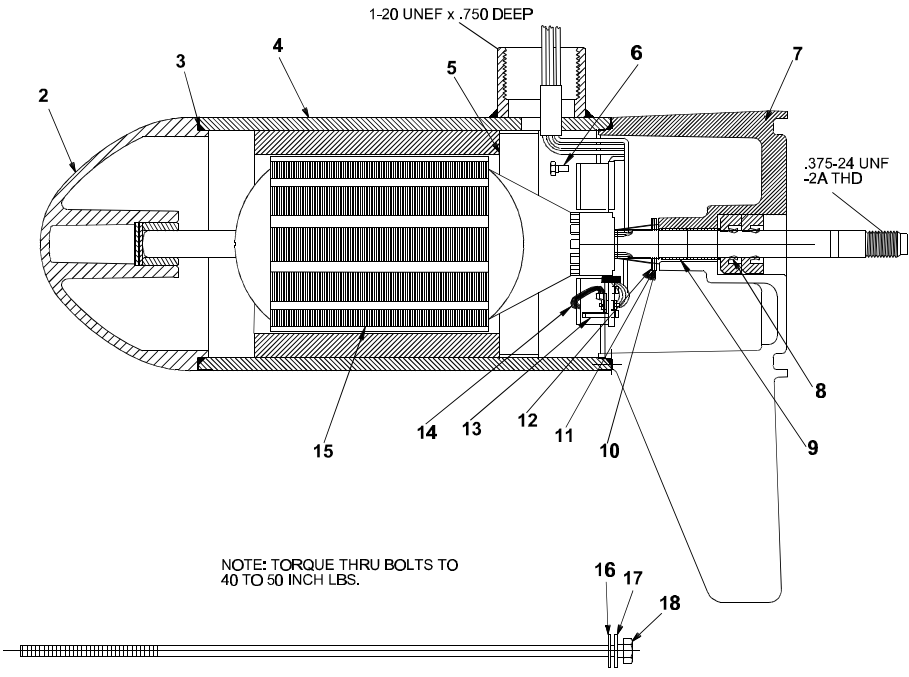

WIRING

