

# MotorGuide REPAIR PARTS

Model: **POWER plus**  
**T43V**

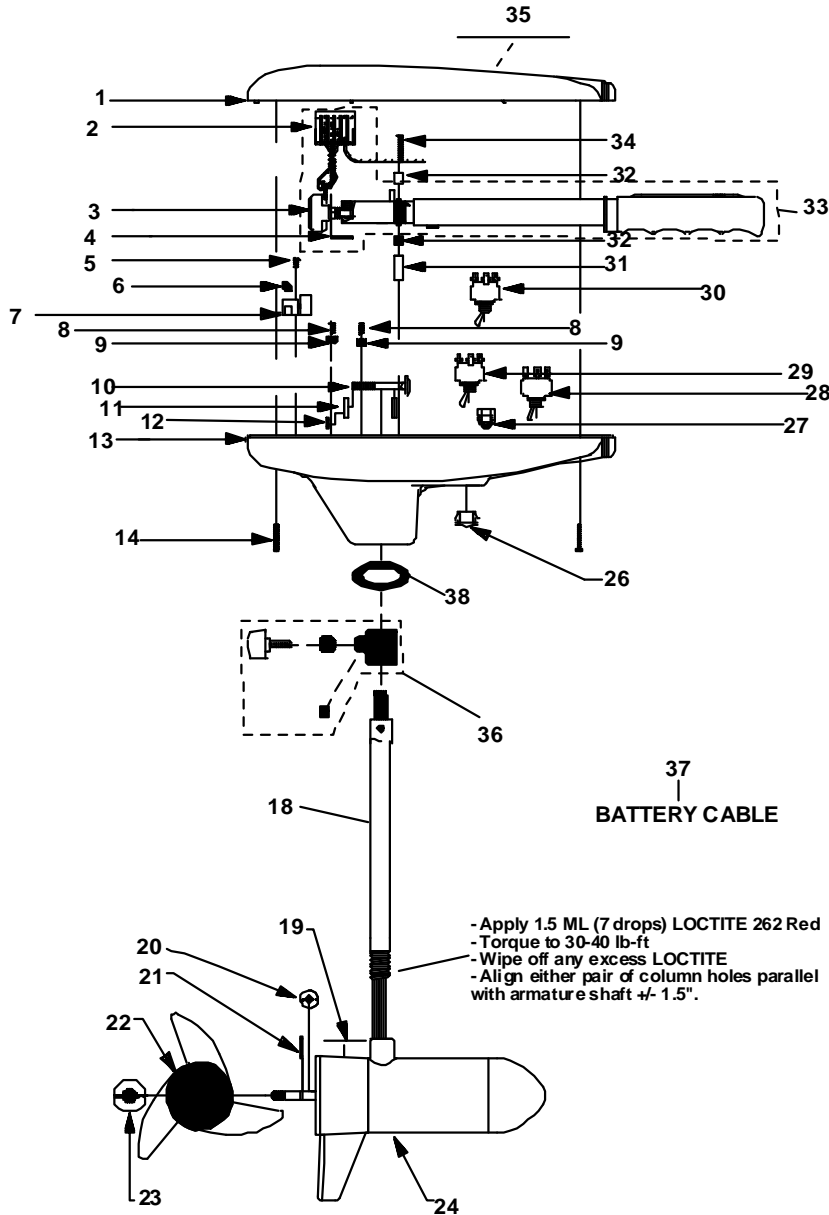

## SPECIFICATIONS:

Year of Intro 1998  
 Thrust 43LBS  
 Volts 12VDC  
 Amp Draw 0 to 48 amps  
 Mount 09 Transom  
 Speeds Variable

## QUICK REFERENCE PARTS GUIDE:

FOR/REV Switch FP153-06  
 DA Board JF157-03  
 MOSFET JF096-07  
 Motor Seal Kit 6220

## PARTS ORDERING & TECH ASSISTANCE

MotorGuide Consumer Relations  
 Phone 918-831-6989  
 Fax 800-982-8093

### Send Returned Goods to:

MotorGuide  
 605 Hwy 12 West  
 Starkville, MS 39760

*Returned Goods must be accompanied with a Returned Goods Authorization. Contact MotorGuide Consumer Relations to obtain RGA.*

KEY	DESCRIPTION	PART #	KEY	DESCRIPTION	PART #
1	TOP HOUSING COVER BLACK	AT053-10	27	GROMMET	GR019-03
2	AMP CONNECTOR	AP029-01	28	TOGGLE SWITCH 3 POSITIONS	FP153-05
3	POTENTIOMETER	AP168-02	29	FWD/REV SWITCH 2 POSITIONS	FP153-06
4	POT BRACKET	AT155-03	30		
5	SELF TAPPING SCREW	AF141-01	31	WIRE BRACKET	AT155-04
6	INSULATING SLEEVE	AT080-01	32	RETAINER CLAMP	AR036-01
7	12 VOLT DURA AMP BOARD	JF157-03	33	HANDLE ASY	AT372-03
8	#10 X 1/2" SCREW	GR133-01	34	8 X 1-3/8 SCREW	AR133-01
9	TERMINAL BLOCK	FT160-01	35	NOMENCLATURE	TT056-09
10	BOLT	TT134-01	36	DEPTH COLLAR ASY	AR158-01
11	CURVED WASHER	TT171-04	37	BATTERY CABLE	BT328-03
12	NYLON LOCK NUT	XT098-02	38	COLUMN SEAL	AT079-01
13	T/H BASE BLACK	AR004-14			
14	SCREW #8 X 1"	LF141-04			
15	BAR KNOB DEPTH ADJUSTMENT	AR082-02			
16	COLUMN CLAMP WASHER	AR171-01			
17	COLUMN SUPPORT NUT	FR098-01			
18	COLUMN 42"	FR049-15			
19	LOWER UNIT DECAL	ET060-04			
20	MONOFILAMENT WASHER	AR175-01			
21	PROP DRIVE PIN	BR102-01			
22	PROP/3 BLADE	AF124-10			
23	PROP NUT	AR099-01			
24	H/O MOTOR	KF397-03			
25	DEPTH ADJUSTMENT COLLAR	AR051-01			
26	HOLE PLUG	FP021-03			

# LOWER UNIT BREAKDOWN

Model:  
**T43V**

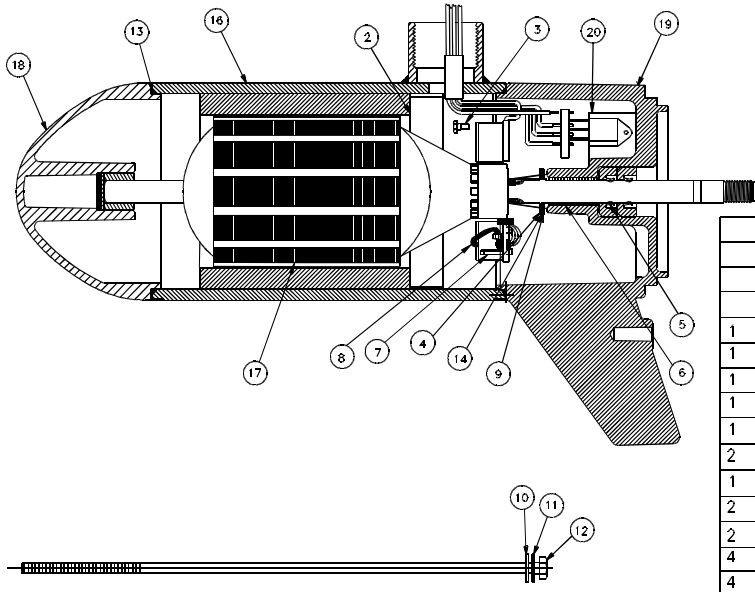

NOTE-TORQUE THRU BOLT, PART MR218-01 DURA AMP SCREW, PART MR229-01 TO 35-40 INCH POUNDS

3.5"-37# DURA AMP MOTOR

REPAIR PARTS LIST

NO. REQ'D	ITEM NO.	DESCRIPTION	PART NO.
1	20	DURA AMP MODULE	JF096-07
1	19	COMM CAP <small>LESS MOTOR &amp; BRUSH ASSY</small>	JF3205-04BSAW
1	18	NOSE CAP S/A	JF3212-01BSAW
1	17	ARMATURE 3.5"	KF3207-01
1	16	HOUSING ASS'Y	KF3210-01BSAW
2	15	DURA AMP SCREW	MR229-01
1	14	WASHER	MR227-01
2	13	"O"-RING SEAL	MR217-01
2	12	THRU BOLT	MR218-01
4	11	THRU BOLT WASHER	MR216-01
4	10	STATIC SEAL	MR222-01
1	9	NYLATRON WASHER	MR226-01
1	8	BRUSH ASS'Y-LESS SPRING	JF3201-01
2	7	BRUSH SPRINGS	MR214-02
1	6	BEARING	MR206-01
2	5	SHAFT SEAL	MR223-01
1	4	"E" RING	MR219-02
2	3	BRUSH CARD SCREW	MR228-01
1	2	RETAINER	JF233-01
1	1	3.5"-37# D.A. MOTOR	KF097-03

## WIRING

### 12V OR 24V D.A. WIRING DIAGRAM

SUBJECT TO DAMAGE BY STATIC ELECTRICITY ASSEMBLE AT STATIC FREE WORK STATION.

