

# MotorGuide REPAIR PARTS

Model: **POWERplus**  
**T28**

## SPECIFICATIONS:

Year of Intro 1998  
 Thrust 28 LBS  
 Volts 12VDC  
 Amp Draw 0 to 48 amps  
 Mount 31 Transom  
 Speeds 5/2

## QUICK REFERENCE PARTS GUIDE:

Handle Asy BT372-06  
 Motor Seal Kit 6220  
 Rotary Switch KT150-02

## PARTS ORDERING & TECH ASSISTANCE

MotorGuide Consumer Relations  
 Phone 918-831-6989  
 Fax 800-982-8093

### Send Returned Goods to:

MotorGuide  
 605 Hwy 12 West  
 Starkville, MS 39760

*Returned Goods must be accompanied with a Returned Goods Authorization. Contact MotorGuide Consumer Relations to obtain RGA.*

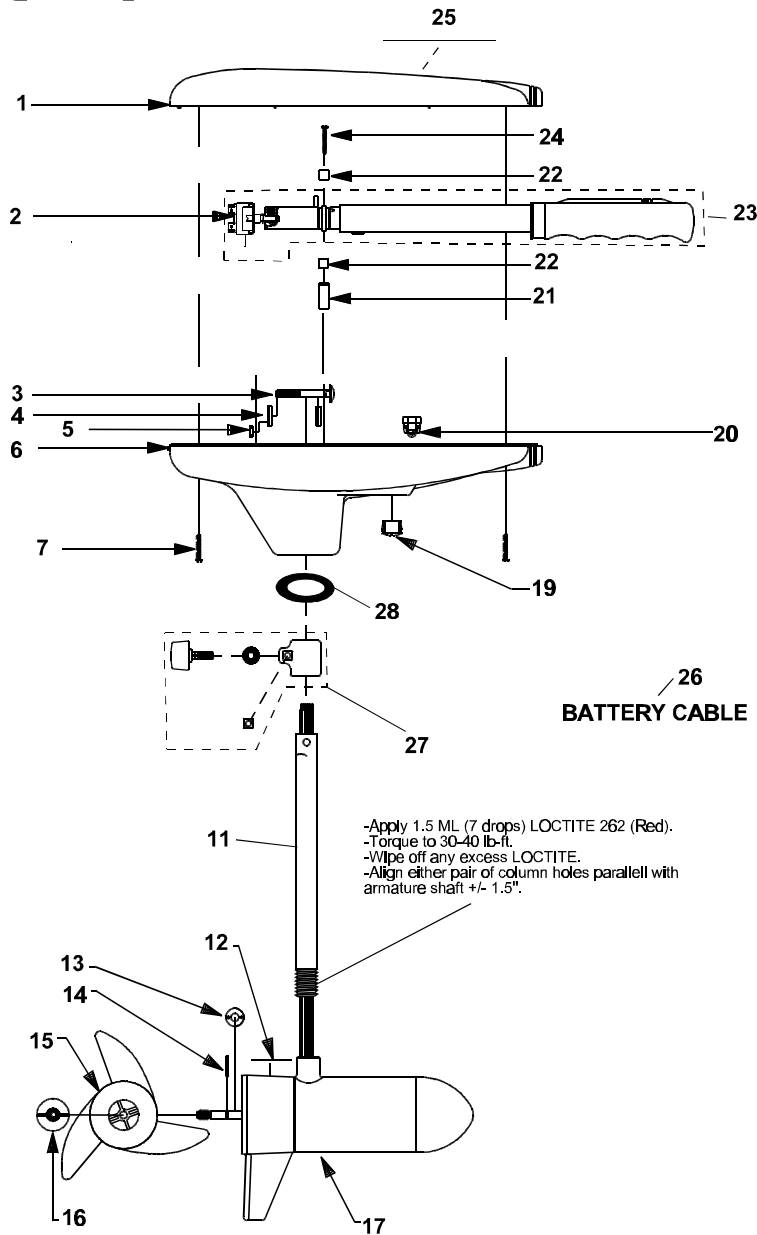

| KEY | DESCRIPTION              | PART #   | KEY | DESCRIPTION | PART #   |
|-----|--------------------------|----------|-----|-------------|----------|
| 1   | COVER BLACK              | AT053-10 | 28  | COLUMN SEAL | AT079-01 |
| 2   | ROTARY SWITCH            | KT150-02 |     |             |          |
| 3   | BOLT                     | TT134-01 |     |             |          |
| 4   | CURVED WASHER            | TT171-04 |     |             |          |
| 5   | NYLON LOCK NUT           | XT098-02 |     |             |          |
| 6   | T/H BASE BLACK           | AR004-14 |     |             |          |
| 7   | SCREW #8 X 1"            | LF141-04 |     |             |          |
| 8   | BAR KNOB                 | AR082-02 |     |             |          |
| 9   | CLAMP WASHER             | AR171-01 |     |             |          |
| 10  | SUPPORT NUT              | FR098-01 |     |             |          |
| 11  | 30" ALUM COLUMN          | MT049-11 |     |             |          |
| 12  | MARINE LOWER UNIT DECAL  | AF060-04 |     |             |          |
| 13  | MONOFILAMENT WASHER      | AR175-01 |     |             |          |
| 14  | PROP DRIVE PIN           | BR102-01 |     |             |          |
| 15  | PROP/ 2 BLADE            | FF124-03 |     |             |          |
| 16  | PROP NUT                 | AR099-01 |     |             |          |
| 17  | MOTOR                    | HF397-04 |     |             |          |
| 18  | DEPTH ADJUSTMENT COLLAR  | AR051-01 |     |             |          |
| 19  | 1/2" HOLE PLUG           | FP021-03 |     |             |          |
| 20  | GROMMET                  | GR019-03 |     |             |          |
| 21  | WIRE BRACKET             | AT155-04 |     |             |          |
| 22  | RETAINER CLAMP           | AR036-01 |     |             |          |
| 23  | 5 SPEED HANDLE ASY 96-97 | BT372-06 |     |             |          |
| 24  | 8 X 1-3/8 SCREW          | AR133-01 |     |             |          |
| 25  | NOMENCLATURE             | PT056-14 |     |             |          |
| 26  | BATTERY CABLE            | TT328-03 |     |             |          |
| 27  | DEPTH COLLAR ASY         | AR158-01 |     |             |          |

# LOWER UNIT BREAKDOWN

**Model:**  
**T28**

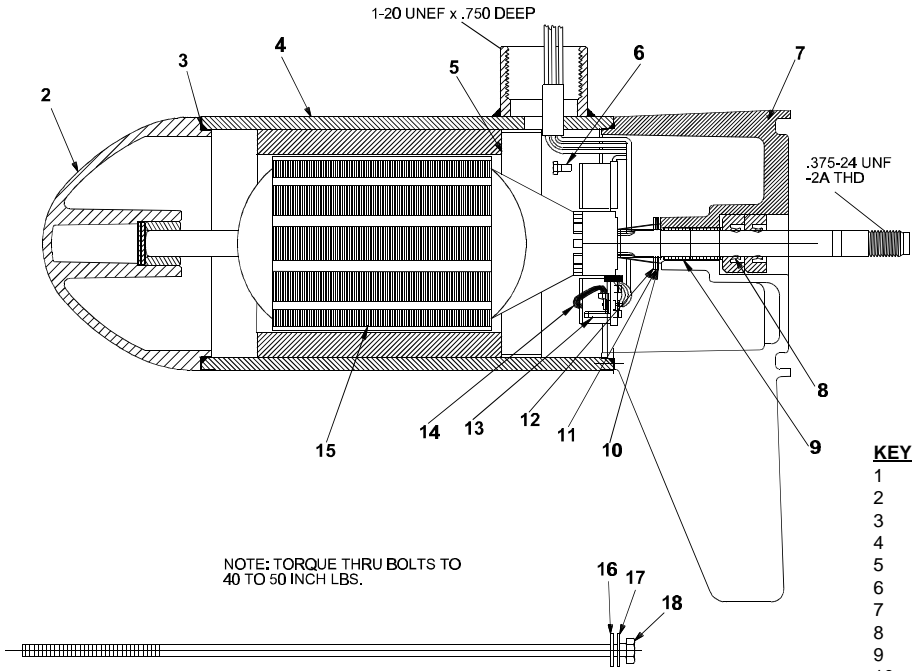

| KEY | QTY | DESCRIPTION           | PART NO.  |
|-----|-----|-----------------------|-----------|
| 1   | X   | MOTOR                 | HF397-04  |
| 2   | 1   | NOSE CAP              | FF3212-01 |
| 3   | 2   | O RING SEAL           | HF217-01  |
| 4   | 1   | HOUSING ASY           | HF3210-01 |
| 5   | 1   | RETAINER              | JF233-01  |
| 6   | 2   | BRUSH CARD SCREW      | MR228-01  |
| 7   | 1   | COMM CAP              | FF3205-01 |
| 8   | 2   | SHAFT SEAL            | MR223-01  |
| 9   | 1   | BEARING               | MR206-01  |
| 10  | 1   | NYLATRON WASHER       | MR226-01  |
| 11  | 1   | WASHER                | MR227-01  |
| 12  | 1   | E RING                | MR219-01  |
| 13  | 2   | BRUSH SPRINGS         | MR214-02  |
| 14  | 1   | BRUSH ASY LESS SPRING | FF3201-01 |
| 15  | 1   | ARMATURE 3"           | HF3207-02 |
| 16  | 4   | STATIC SEAL           | MR222-01  |
| 17  | 4   | THRU BOLT WASHER      | MR216-01  |
| 18  | 2   | THRU BOLT             | MR218-06  |

## WIRING

