

MotorGuide® REPAIR PARTS

Model: **POWERplus**
T22

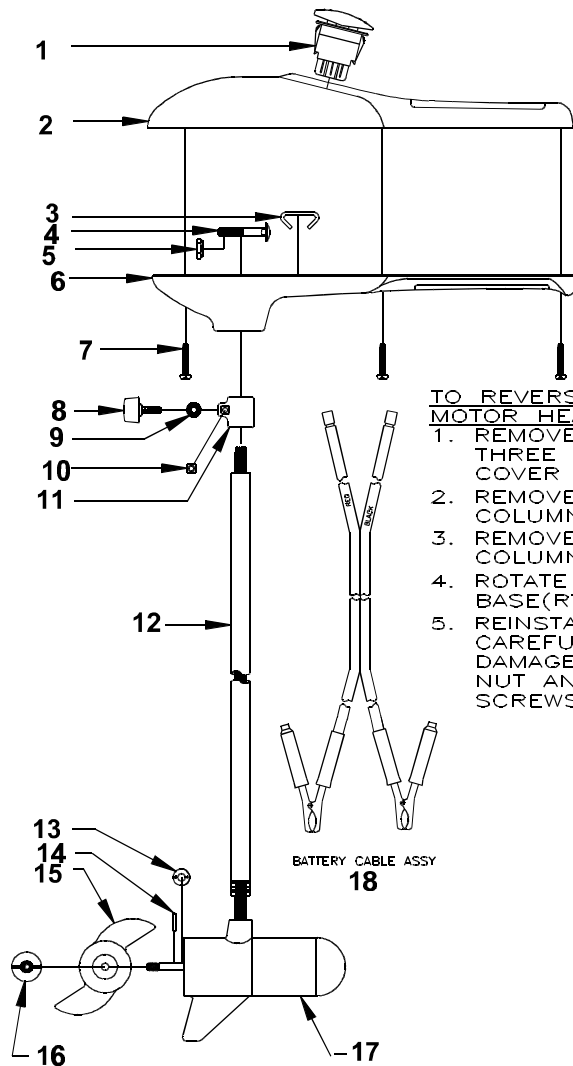

**TO REVERSE TROLLING
MOTOR HEAD:**

1. REMOVE THE THREE TOP HOUSING COVER SCREWS(LF141-04)
2. REMOVE THE COLUMN NUT(XT098-02)
3. REMOVE THE COLUMN BOLT(RT134-01)
4. ROTATE THE TOP HOUSING BASE(RT004-01) 180 DEGREES
5. REINSTALL THE BOLT, (BEING CAREFUL NOT TO NICK OR DAMAGE THE MOTOR WIRES), NUT AND TOP HOUSING SCREWS IN REVERSE ORDER

SPECIFICATIONS:

Year of Intro	1998
Thrust	22LBS
Volts	12VDC
Amp Draw	0 to 27 amps
Mount	31 Transom
Speeds	2 Forward

QUICK REFERENCE PARTS GUIDE:

Rocker Switch	RT152-01
Comm Cap	RT3205-02

PARTS ORDERING & TECH ASSISTANCE

MotorGuide Consumer Relations
Phone 918-831-6989
Fax 800-982-8093

Send Returned Goods to:

MotorGuide
605 Hwy 12 West
Starkville, MS 39760

Returned Goods must be accompanied with a Returned Goods Authorization. Contact MotorGuide Consumer Relations to obtain RGA.

KEY	DESCRIPTION	PART #
1	ROCKER SWITCH	RT152-01
2	TOP COVER	RT053-04
3	RING CLAMP	FP040-01
4	BOLT	RT134-01
5	NUT	XT098-02
6	T/H BASE BLACK	RT004-01
7	SCREW #8 X 1"	LF141-04
8	BAR KNOB	AR082-02
9	CLAMP WASHER	AR171-01
10	SUPPORT NUT	FR098-01
11	DEPTH COLLAR	AR051-01
12	COLUMN 30"	RT049-05
13	MONOFILAMENT WASHER	AR175-01
14	PROP DRIVE PIN	BR102-01
15	PROP	FF124-06
16	PROP NUT	AR099-01
17	MOTOR	RT397-06
18	BATTERY CABLE	RT328-01

PARTS NOT ILLUSTRATED
TOP HOUSING DECAL TM056-27

LOWER UNIT BREAKDOWN

Model:
T22

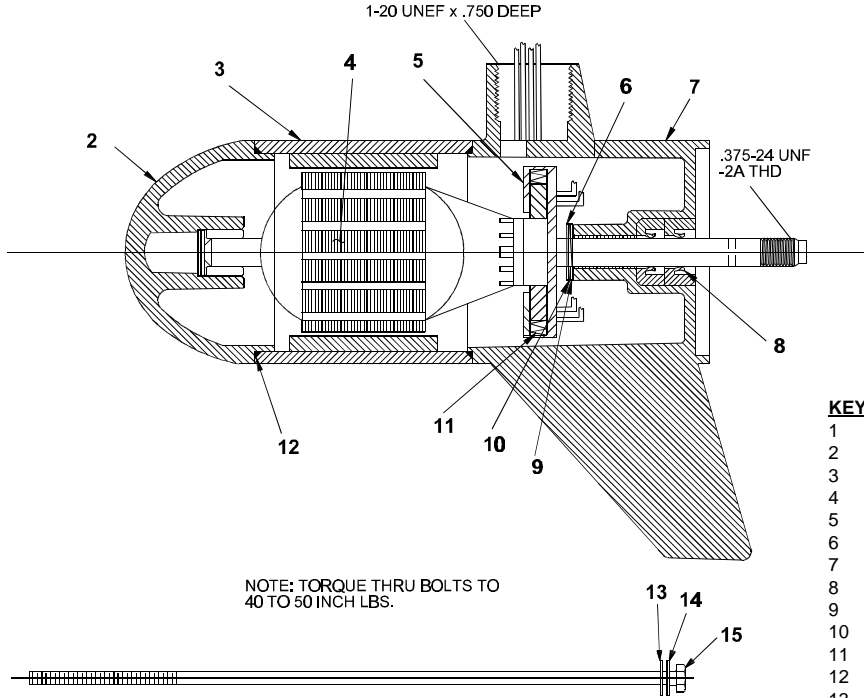

KEY	QTY	DESCRIPTION	PART NO.
1	X	MOTOR	RT397-06
2	1	NOSE CAP	FF3212-01
3	1	HOUSING ASY	RT3210-01
4	1	ARMATURE 3"	RT3207-01
5	1	BRUSH ASY LESS SPRING	RT3201-01
6	1	E RING	MR219-02
7	1	COMM CAP	RT3205-02
8	2	SHAFT SEAL	MR223-01
9	1	NYLATRON WASHER	MR226-01
10	1	WASHER	MR227-01
11	2	BRUSH SPRINGS	MR214-02
12	2	O RING SEAL	HF217-01
13	4	STATIC SEAL	MR222-01
14	4	THRU BOLT WASHER	MR216-01
15	2	THRU BOLT	MR218-06

WIRING

