

SPECIFICATIONS:

Year of Intro	1996
Thrust	41 LBS
Volts	12VDC
Amp Draw	0 to 48 amps
Mount	01 Bow
Speeds	5 Forward

QUICK REFERENCE PARTS GUIDE:

Momentary switch	AP151-01
Toggle Switch	FP153-03
Motor Seal Kit	6220
Rotary Switch	HF150-01

PARTS ORDERING & TECH ASSISTANCE

MotorGuide Consumer Relations
Phone 918-831-6989
Fax 800-982-8093

Send Returned Goods to:

MotorGuide
605 Hwy 12 West
Starkville, MS 39760

Returned Goods must be accompanied with a Returned Goods Authorization. Contact MotorGuide Consumer Relations to obtain RGA.

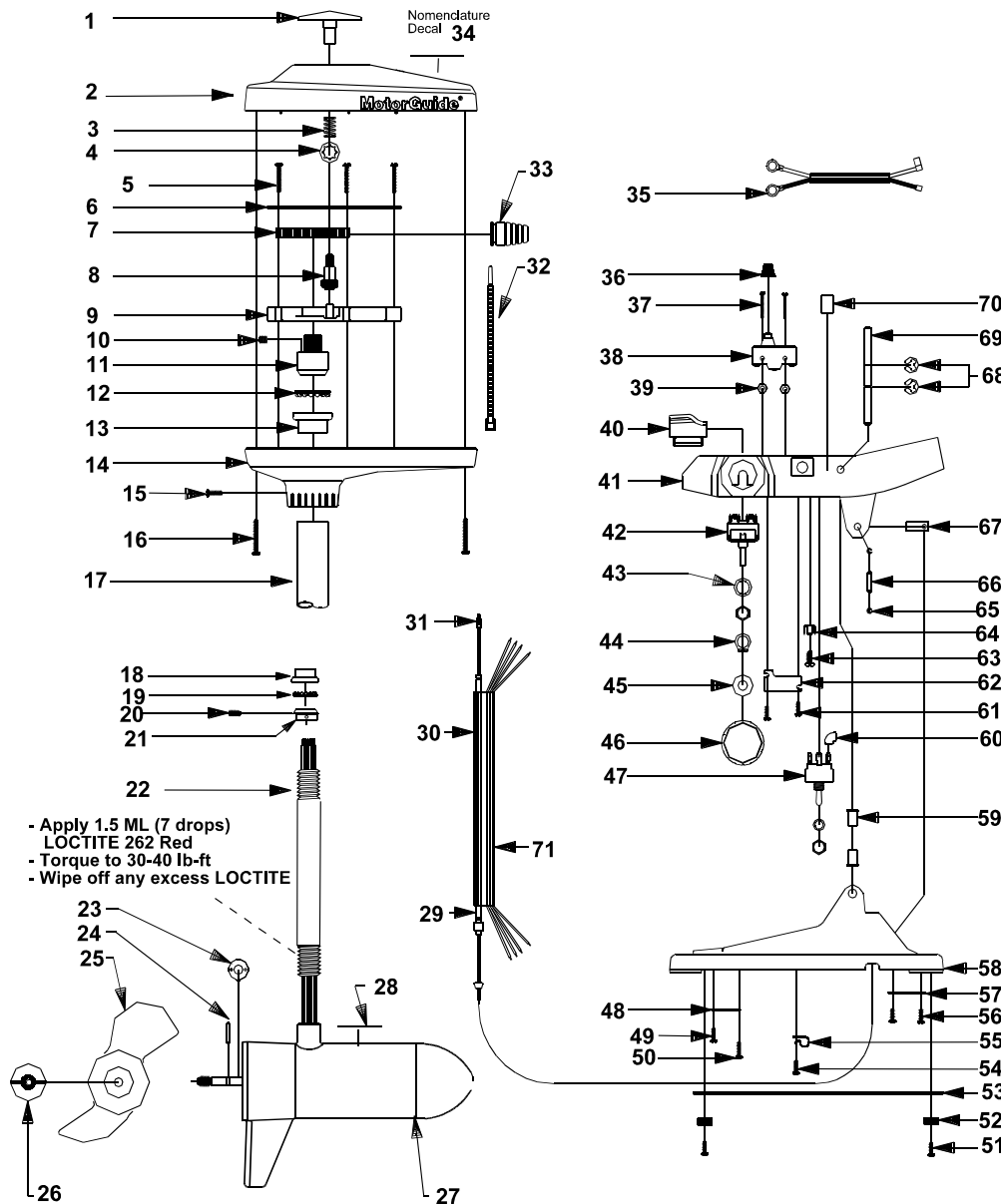

KEY	DESCRIPTION	PART #	KEY	DESCRIPTION	PART #	KEY	DESCRIPTION	PART #
1	INDICATOR BLACK	JF078-03	26	PROP NUT	AR099-01	51	6 X 1/2 SCREW	AF135-01
2	TOP HOUSING COVER BLACK	JF053-19	27	LOWER UNIT	DF397-02	52	FOOT PEDAL PAD	KP023-01
3	COMPRESSION SPRING	AF014-01	28	LOWER UNIT DECAL	ET060-04	53	WEIGHT PLATE ASY	LP123-01
4	TINNERMAN CLIP	AF046-01	29	63" CONTROL CABLE STUD ASY	9377	54	6 X 1/2 SCREW	AF135-01
5	#6 RACK GUIDE SCREW	AF133-01	30	69" CONTROL CABLE STUD ASY	9767	55	CABLE CLAMP	KP036-01
6	RACK GUIDE COVER	AF127-01	31	69" 5 SP CONTROL CABLE ASY	LP327-06	56	SCREWS	IR133-01
7	RACK	AP125-01	32	CONTROL CABLE STUD	LP327-08	57	BATTERY CLAMP	KP036-02
8	INDICATOR GEAR	AF069-01	33	CABLE TIE	AP141-01	58	FOOT PEDAL BASE	LP003-01
9	RACK GUIDE	AF126-01	34	GROMMET	AF030-01	59	SHAFT BUSHING	KP021-01
10	1/4 NUT SET SCREW	AF142-01	35	NOMENCLATURE	AP071-01	60	INSULATING SLEEVE	AT080-01
11	NUT-SUB ASY	AF398-02	36	BATTERY CABLE ASY	FR056-08	61	6 X 1/2 SCREW	AF135-01
12	BALL BEARING	AF005-01	37	MICRO SWITCH BOOT	EP328-04	62	RETAINER PLATE	LP123-03
13	BEARING CUP	AF007-01	38	#6 32 X 1 1/2 SCREW	KP157-01	63	#10 X 1/2" SCREW	GR133-01
14	TOP HOUSING BASE F/O BLACK	JF004-03	39	MICRO SWITCH	LP135-01	64	TERMINAL (4PRONG)	FT160-03
15	6 X 5/8 SCREW	AP133-01	40	6 - 32 NUT S.S	AP151-01	65	E RING	FP046-01
16	8 X 1-3/8 SCREW	AR133-01	41	MICRO BUTTON	SP098-02	66	CABLE PIVOT PIN	AP105-01
17	36" OUTER TUBE	AF165-01	42	FOOT PEDAL	LP026-01	67	CABLE PIVOT	LP091-01
18	BEARING CUP	AF165-06	43	ROTARY SWITCH	LP101-03	68	E RING	BK046-01
19	BALL BEARING	FM007-01	44	LOCK WASHER 3/8	HF150-01	69	FOOT PEDAL ROCKER PIN	LP102-01
20	SET SCREW	FM005-01	45	GRIP RING	KP171-01	70	CON/MOM/HBP SWITCH DECAL	LP057-03
21	BEARING CONE	AF143-01	46	NYLON WASHER	LP046-01	71	63" ELECTRIC CABLE JACKET	MM9006-02
22	36" .187 ALUM. F/O COLUMN	AF006-01	47	5 SPEED KNOB	AK171-02		69" ELECTRIC CABLE JACKET	MM9006-03
23	MONOFILAMENT WASHER	DF049-01	48	TOGGLE SWITCH 3 POSITIONS	LP082-07			
24	PROP DRIVE PIN	DF049-02	49	CABLE PLATE	FP153-03			
25	3 BLADE NINJA PROP	AR175-01	50	#6 SELF TAP SCREW	KP123-01			
		BR102-01		6 X 1/2 SCREW	EK135-01			
		AF124-10			AF135-01			

LOWER UNIT BREAKDOWN

Model:
SF350

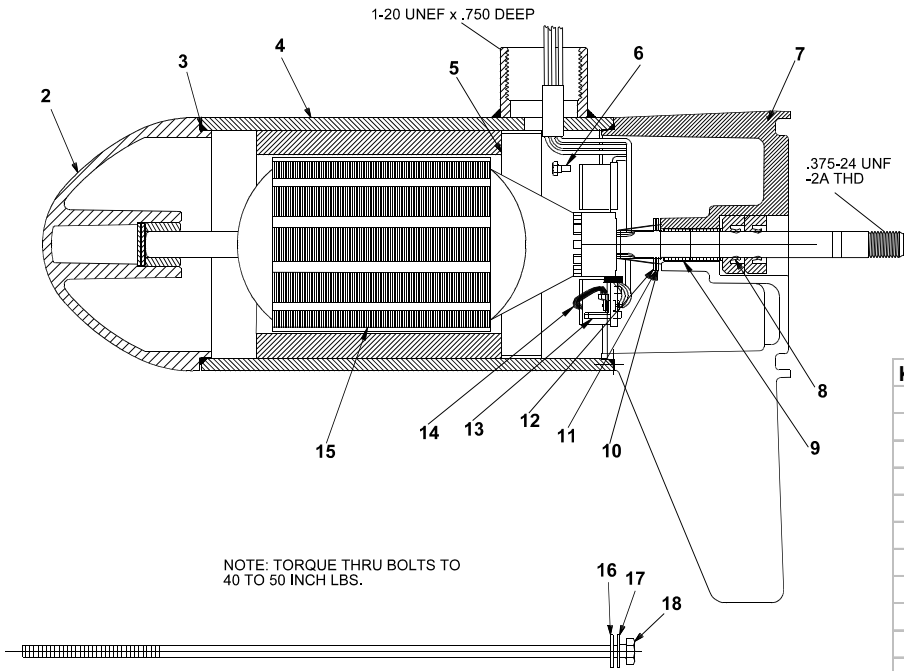

KEY #	QTY	DESCRIPTION	PART NO.
1	X	MOTOR	DF397-02
2	1	NOSE CAP	JF3212-01
3	2	O RING SEAL	MR217-01
4	1	HOUSING ASSY	JF3210-01
5	1	RETAINER	JF233-01
6	2	BRUSH CARD SCREW	MR228-01
7	1	COMM CAP	DF3205-01
8	2	SHAFT SEAL	MR223-01
9	1	BEARING	MR206-01
10	1	NYLATRON WASHER	MR226-01
11	1	WASHER	MR227-01
12	1	E RING	MR219-01
13	2	BRUSH SPRINGS	MR214-02
14	1	BRUSH ASSY LESS SPRING	DF3201-01
15	1	ARMATURE 3.5"	CF3207-01
16	4	STATIC SEAL	MR222-01
17	4	THRU BOLT WASHER	MR216-01
18	2	THRU BOLT	MR218-02

WIRING

12V WIRING DIAGRAM

