

MotorGuide REPAIR PARTS

Model: **POWER plus**
QSB67

MotorGuide
HYPER
 DRIVE

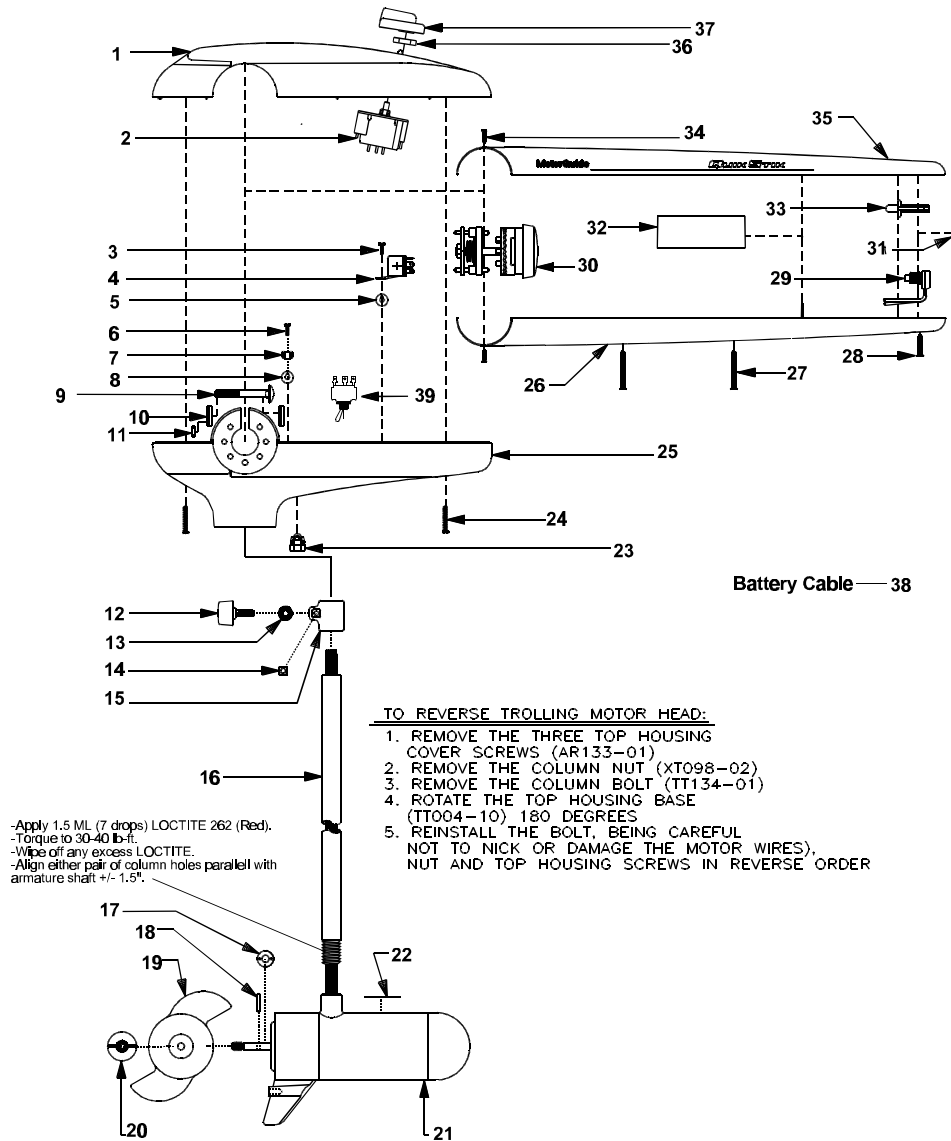

SPECIFICATIONS:

Year of Intro	1999
Thrust	67LBS
Volts	12/24VDC
Amp Draw	0 to 34 amps
Mount	15 Bow
Speeds	10/5

QUICK REFERENCE PARTS GUIDE:

Rotary Switch	KT150-02
Relay	TT128-02
ON/OFF Switch	TT3149-03

PARTS ORDERING & TECH ASSISTANCE

MotorGuide Consumer Relations
 Phone 918-831-6989
 Fax 800-982-8093

KEY#	PART#	DESCRIPTION	KEY#	PART#	DESCRIPTION
1	TT053-11	QS T/H COVER	26	FT072-02	LOWER HANDLE QS BLACK
2	KT150-02	ROTARY SWITCH	27	TT133-03	SCREW #6X1"
3	GR133-01	#10 X 1/2" SCREW	28	TT133-02	SCREW #6X.75
4	TT128-01	12 VOLT RELAY	29	TT3149-03	ON/OFF SWITCH ASY QS
5	TT098-03	ON SERT/PAL NUT	30	TT372-04	HANDLE/CLUTCH ASY QS
6	GR133-01	#10 X 1/2" SCREW	31	TT177-02	SWITCH BOOT
7	FT160-03	TERMINAL (4 PRONG)	32	FT057-05	N/A
8	TT098-03	ON SERT/PAL NUT	33	TT001-04	ACTUATOR ON/OFF
9	TT134-01	BOLT	34	TT133-01	SCREW #6X.437
10	TT171-04	CURVED WASHER	35	TT072-12	UPPER HANDLE PWR PLUS
11	XT098-02	NYLON LOCK NUT	36	AT098-01	PAL NUT
12	AR082-02	KNOB DEPTH ADJUSTMENT	37	TT082-06	ROTARY KNOB
13	AR171-01	COLUMN CLAMP WASHER	38	AT328-02	BATTERY CABLE ASSEMBLY
14	FR098-01	COLUMN SUPPORT NUT	39	FP153-04	TOGGLE SWITCH
15	AR051-01	DEPTH ADJUSTMENT COLLAR			
16	TT049-05	36" COLUMN FOR QUIK STIK			
	FR049-19	42" COLUMN SS			
17	AR175-01	MONOFILAMENT WASHER			
18	BR102-01	PROP DRIVE PIN			
19	AF124-07	2 BLADE PROP			
20	AR099-01	PROP NUT			
21	VF397-01	MOTOR			
22	ET060-05	LOWER UNIT DECAL			
23	GR019-01	BATTERY CABLE BUSHING			
24	AR133-01	8 X 1-3/8 SCREW			
25	TT004-10	T/H BASE QS GENERIC			

PARTS NOT ILLUSTRATED

AT056-18	DECAL, TOP HOUSING
MM5604	OWNERS MANUAL

LOWER UNIT BREAKDOWN

Model:
QSB67

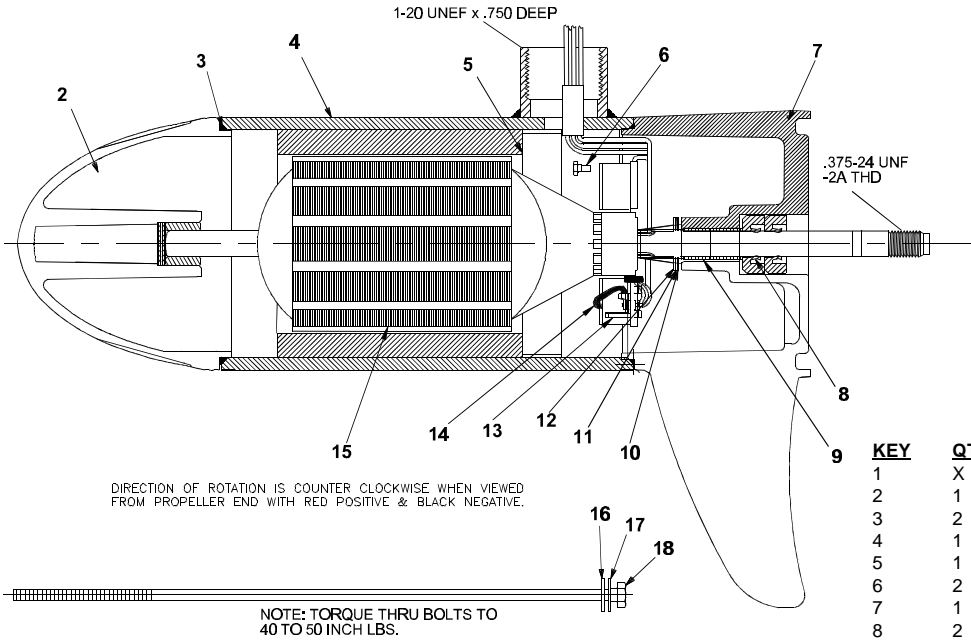

KEY	QTY	DESCRIPTION	PART NO.
1	X	MOTOR	VF397-01
2	1	NOSE CAP	XF3212-01
3	2	O RING SEAL	MR217-01
4	1	HOUSING ASY	UF3210-01
5	1	RETAINER	JF233-01
6	2	BRUSH CARD SCREW	MR228-01
7	1	COMM CAP	VF3205-01
8	2	SHAFT SEAL	MR223-01
9	1	BEARING	MR206-01
10	1	NYLATRON WASHER	MR226-01
11	1	WASHER	MR227-01
12	1	E RING	MR219-02
13	2	BRUSH SPRINGS	MR214-02
14	1	BRUSH ASY LESS SPRING	VF3201-01
15	1	ARMATURE 3.5"	UF3207-01
16	4	STATIC SEAL	MR222-01
17	4	THRU BOLT WASHER	MR216-01
18	2	THRU BOLT	MR218-02

WIRING

