

SPECIFICATIONS:

Year of Intro	1994
Thrust	55LBS
Volts	24VDC
Amp Draw	0 to 33 amps
Mount	20 Bow
Speeds	Variable

QUICK REFERENCE PARTS GUIDE:

MOSFET	JF096-08
Motor Seal Kit	6220
Transmitter	NP169-01

PARTS ORDERING & TECH ASSISTANCE

MotorGuide Consumer Relations
Phone 918-831-6989
Fax 800-982-8093

Send Returned Goods to:
MotorGuide
605 Hwy 12 West
Starkville, MS 39760

Returned Goods must be accompanied with a Returned Goods Authorization. Contact MotorGuide Consumer Relations to obtain RGA.

KEY#	PART#	DESCRIPTION	KEY#	PART#	DESCRIPTION	KEY#	PART#	DESCRIPTION
1	LF069-04	LAZER GEAR/INDICATOR	18	LF049-08	54" SS COLUMN	38	LF170-01	RECEIVER
2	LF014-01	SPRING/INDICATOR	19	AR099-01	60" SS COLUMN	39	IR133-01	SELF TAPPING SCREW
3	LF141-02	SCREW #4 X 7/8	20	JF397-05	F/O MOTOR	40	LF69-08	LARGE PINION GEAR
4	LF125-01	RACK	21	BR102-01	PROP NUT	41	LF141-03	SCREW #8X3/4
5	LF126-01	RACK GUIDE	22	LF060-04	3.5 NINJA 2 BLADE PROP	42	LF127-01	RACK GUIDE COVER
6	LF064-01	COLUMN COUPLER	23	LF060-04	PROP DRIVE PIN	43	LF098-01	TINNERMAN CLIP
7	LF068-03	PINION GEAR	24	LF060-04	LOWER UNIT DECAL LAZER	44	LF053-29	LAZER GENERIC T/H COVER
8	LF141-02	SCREW #4 X 7/8	25	RK171-01	BATTERY CABLE ASY	45	LF141-06	SCREW #6X1/2 PLASTIC
9	LF3126-02	DRIVE MOTOR ASSY 24V	26	PM160-01	TERMINAL	46	LF078-09	LAZER INDICATOR
10	PM160-01	TERMINAL	27	LF111-02	POP RIVET .126-.187 D6	47	LF053-29	LAZER T/H COVER ASSY
11	LF141-04	SCREW #8 X 1"	28	LF004-03	T/H BASE	48	NP300-05	LAZER PEDAL ASY
12	AF165-06	(46") OUTER TUBE	29	AF030-01	CABLE TIE	49	NP157-01	TRANSMITTER
13	AF165-07	(30") OUTER TUBE	30	AF141-01	SCREW, SELF TAPPING	50	NP133-01	SCREW
14	AF165-08	(36") OUTER TUBE	31	LF157-02	LAZER 24V ES/RF BOARD	51	NP063-02	GASKET ORING
15	AF165-01	(13") OUTER TUBE	32	AF141-01	SELF TAPPING SCREW	52	NP053-03	BATTERY DOOR
16	AF007-01	RETAINER/BEARING CUP	33	BR161-03	20-14 FLAG TERM/STRIP G2	53	AF135-01	SCREW
17	AF005-01	BEARING	34	AT080-01	INSULATING SLEEVE			
	AF006-01	RETAINER/BEARING	35	FM007-01	BEARING CUP			
	AF143-01	SET SCREW	36	FM005-01	BALL BEARING			
	LF049-03	36" SS COLUMN	37	LF111-01	POP RIVET .376-.500 D6			
	LF049-04	42" SS COLUMN		LF102-03	STANDOFF			
	LF049-05	50" SS COLUMN						

PARTS NOT ILLUSTRATED
LF056-08 TOP HOUSING DECAL

LOWER UNIT BREAKDOWN

Models:
L500RF

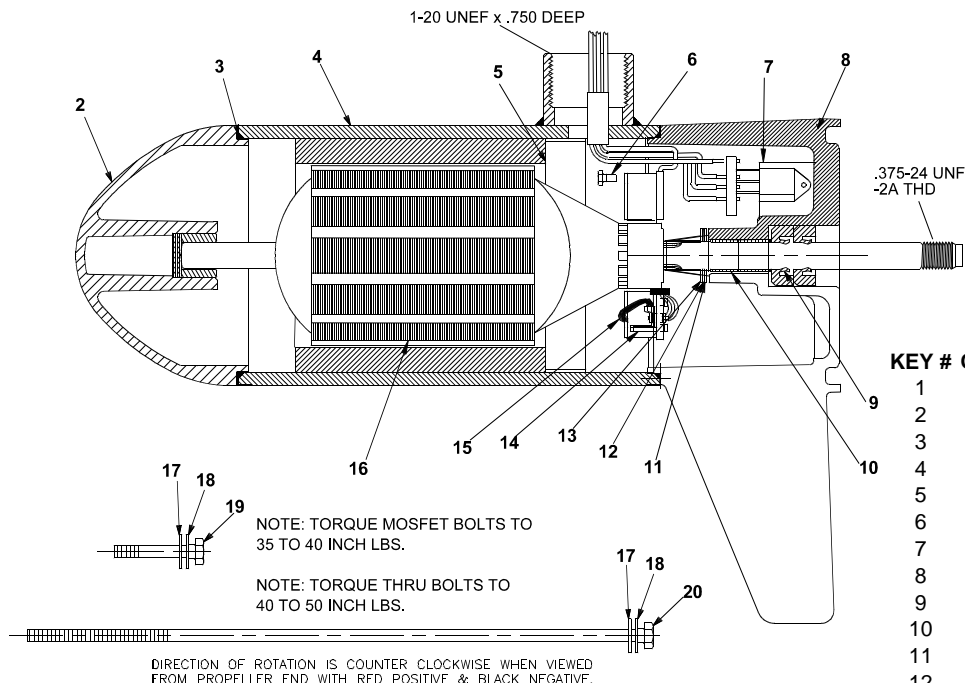

KEY #	QTY	DESCRIPTION	PART NO.
1	X	MOTOR	JF397-05
2	1	NOSE CAP	JF3212-01
3	2	O RING SEAL	MR217-01
4	1	HOUSING ASSY	JF3210-01
5	1	RETAINER	JF233-01
6	2	BRUSH CARD SCREW	MR228-01
7	1	DURA AMP MODULE	JF096-08
8	1	COMM CAP	JF3205-01
9	2	SHAFT SEAL	MR223-01
10	1	BEARING	MR206-01
11	1	NYLATRON WASHER	MR226-01
12	1	WASHER	MR227-01
13	1	E RING	MR219-01
14	2	BRUSH SPRINGS	MR214-02
15	1	BRUSH ASSY LESS SPRING	JF3201-04
16	1	ARMATURE 3.5"	JF3207-01
17	4	STATIC SEAL	MR222-01
18	4	THRU BOLT WASHER	MR216-01
19	2	DURA AMP SCREW	MR229-01
20	2	THRU BOLT	MR218-02

WIRING

