

# MotorGuide® REPAIR PARTS

Models:  
**L500ES**

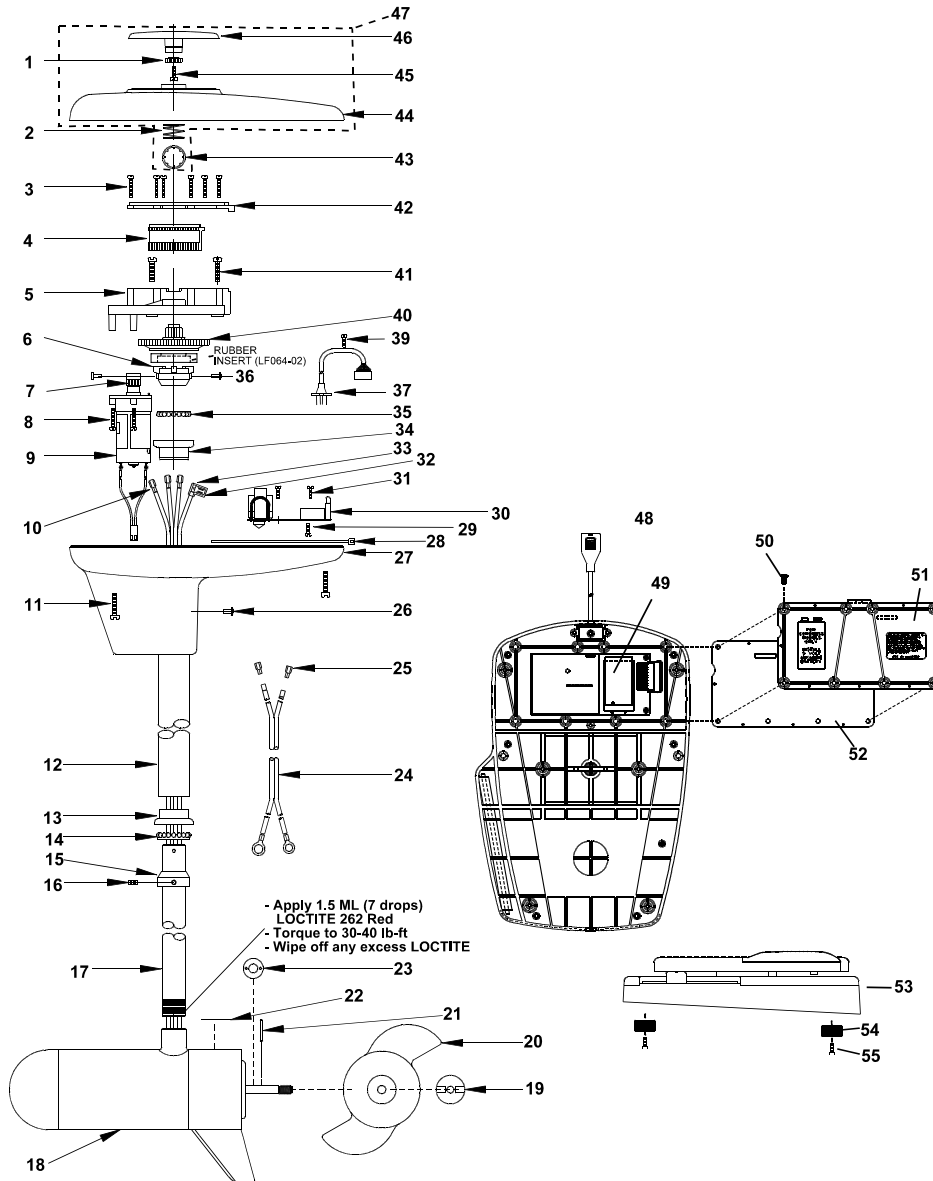

## SPECIFICATIONS:

Year of Intro	1994
Thrust	55LBS
Volts	24VDC
Amp Draw	0 to 33 amps
Mount	20 Bow
Speeds	Variable

## QUICK REFERENCE PARTS GUIDE:

MOSFET	JF096-08
Motor Seal Kit	6220

**Note:** Should the original pedal need service, upgrade pedal to Lazer II ES pedal with housing receptacle.

## PARTS ORDERING & TECH ASSISTANCE

MotorGuide Consumer Relations  
Phone 918-831-6989  
Fax 800-982-8093

### Send Returned Goods to:

MotorGuide  
605 Hwy 12 West  
Starkville, MS 39760

*Returned Goods must be accompanied with a Returned Goods Authorization. Contact MotorGuide Consumer Relations to obtain RGA.*

KEY#	PART#	DESCRIPTION	KEY#	PART#	DESCRIPTION	KEY#	PART#	DESCRIPTION
1	LF069-04	LAZER GEAR/INDICATOR	20	AF124-05	3.5 NINJA 2 BLADE PROP	46	LF078-09	LAZER INDICATOR
2	LF014-01	SPRING/INDICATOR	21	BR102-01	PROP DRIVE PIN	47	LF053-29	LAZER II GENERIC TH COVER
3	LF141-02	SCREW #4 X 7/8	22	LF060-04	LOWER UNIT DECAL LAZER	48	NP327-03	CONTROL CABLE
4	LF125-01	RACK	23	RK171-01	NYLON WASHER .125" THICK	49	NP157-04	LAZER II INTERFACE BD ES
5	LF126-01	RACK GUIDE	24	LF328-01	BATTERY CABLE ASY	50	XF141-06	#6X32X7/16 SCREW
6	LF064-01	COLUMN COUPLER	25	PM160-01	TERMINAL	51	NP012-01	LAZER II BATTERY DOOR
7	LF068-03	PINION GEAR	26	LF111-02	POP RIVET .126-.187 D6	52	NP079-02	LAZER II DOOR GASKET
8	LF141-02	SCREW #4 X 7/8	27	LF004-02	T/H BASE	53	NP300-10	LAZER II PEDAL ASY
9	LF3126-02	DRIVE MOTOR ASSY 24	28	AF030-01	CABLE TIE	54	XP023-01	FOOT PEDAL PADS
10	PM160-01	TERMINAL	29	AF141-01	SCREW, SELF TAPPING	55	XF135-01	SCREW, PAD
11	LF141-04	SCREW #8 X 1"	30	LF157-02	LAZER II 24V ES/RF BOARD			
12	AF165-06	(46") OUTER TUBE	31	AF141-01	SELF TAPPING SCREW			
	AF165-07	(30") OUTER TUBE	32	BR161-03	20-14 FLAG TERMI/STRIP G2			
	AF165-08	(36") OUTER TUBE	33	AT080-01	INSULATING SLEEVE			
	AF165-01	(13") OUTER TUBE	34	FM007-01	BEARING CUP			
13	FM007-01	RETAINER/ BEARING CUP	35	FM005-01	BALL BEARING			
14	FM005-01	BEARING	36	LF111-01	POP RIVET .376-.500 D6			
15	AF006-01	RETAINER/BEARING	37	LF327-02	HOUSING CABLE			
16	AF143-01	SET SCREW	38					
17	LF049-03	36" SS COLUMN	39	IR133-01	SELF TAPPING SCREW			
	LF049-04	42" SS COLUMN	40	LF69-08	LARGE PINION GEAR			
	LF049-05	50" SS COLUMN	41	LF141-03	SCREW #8X3/4			
	LF049-08	54" SS COLUMN	42	LF127-01	RACK GUIDE COVER			
	LF049-09	60" SS COLUMN	43	LF098-01	TINNERMAN CLIP			
18	JF397-05	F/O MOTOR	44	LF053-29	LAZER II GENERIC TH COVER			
19	AR099-01	PROP NUT	45	LF141-06	SCREW #6X1/2 PLASTIC			

## PARTS NOT ILLUSTRATED

LF056-09	TOP HOUSING DECAL
----------	-------------------

# LOWER UNIT BREAKDOWN

**Models:**  
**L500ES**

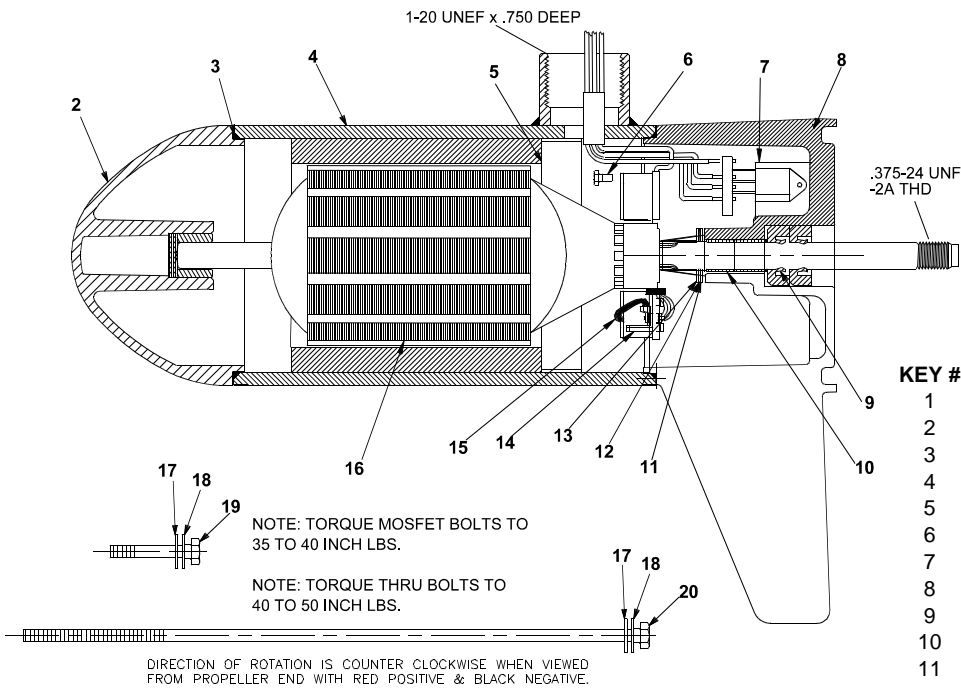

KEY #	QTY	DESCRIPTION	PART NO.
1	X	MOTOR	JF397-05
2	1	NOSE CAP	JF3212-01
3	2	O RING SEAL	MR217-01
4	1	HOUSING ASSY	JF3210-01
5	1	RETAINER	JF233-01
6	2	BRUSH CARD SCREW	MR228-01
7	1	DURA AMP MODULE	JF096-08
8	1	COMM CAP	JF3205-01
9	2	SHAFT SEAL	MR223-01
10	1	BEARING	MR206-01
11	1	NYLATRON WASHER	MR226-01
12	1	WASHER	MR227-01
13	1	E RING	MR219-01
14	2	BRUSH SPRINGS	MR214-02
15	1	BRUSH ASSY LESS SPRING	JF3201-04
16	1	ARMATURE 3.5"	JF3207-01
17	4	STATIC SEAL	MR222-01
18	4	THRU BOLT WASHER	MR216-01
19	2	DURA AMP SCREW	MR229-01
20	2	THRU BOLT	MR218-02

## WIRING

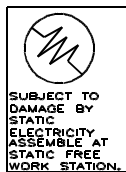
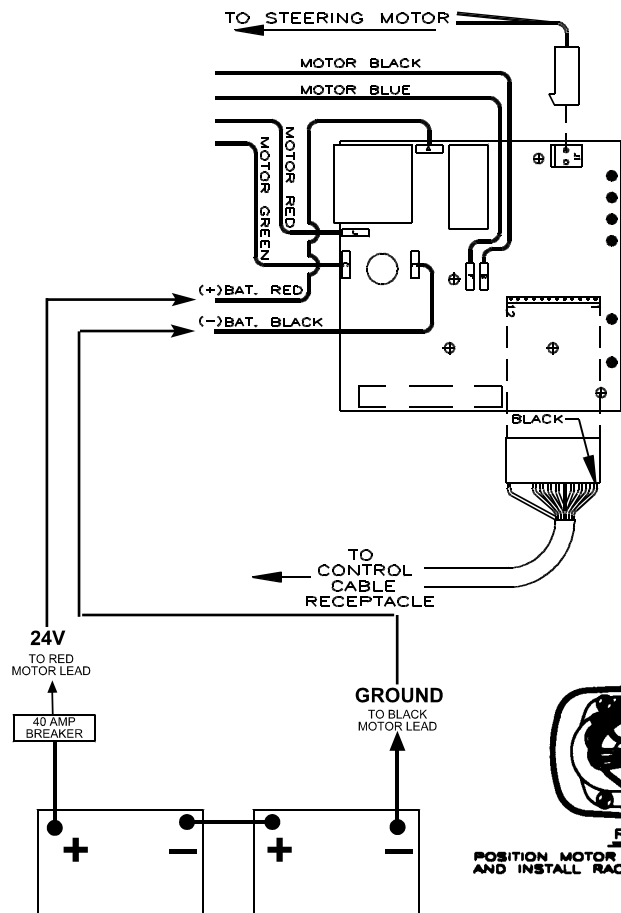

Lubricate wire exiting pinion with non washout grease and bend wires flat to clear indicator gear teeth.

Battery cable leads to be bent at 90 degrees. Leads must be at or below top of Control electronics board.

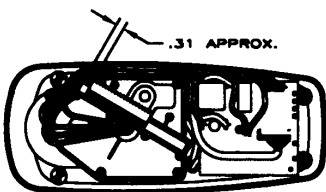

**RACK INSTALLATION**  
POSITION MOTOR IN LINE WITH TOP HOUSING (SEE BELOW) AND INSTALL RACK APPROX. 5/16 FROM END OF TRAVEL

