

MotorGuide REPAIR PARTS

Model:
HVT3000

SPECIFICATIONS:

Year of Intro	1998
Thrust	30LBS
Volts	12VDC
Amp Draw	0 to 48 amps
Mount	03 Transom
Speeds	5/2

PARTS ORDERING & TECH ASSISTANCE

MotorGuide Consumer Relations
Phone 918-831-6989
Fax 800-982-8093

Send Returned Goods to:
MotorGuide
605 Hwy 12 West
Starkville, MS 39760

Returned Goods must be accompanied with a Returned Goods Authorization. Contact MotorGuide Consumer Relations to obtain RGA.

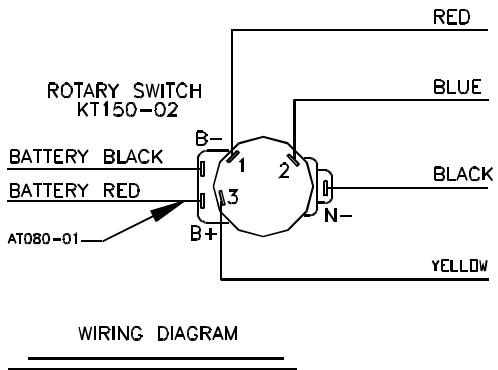
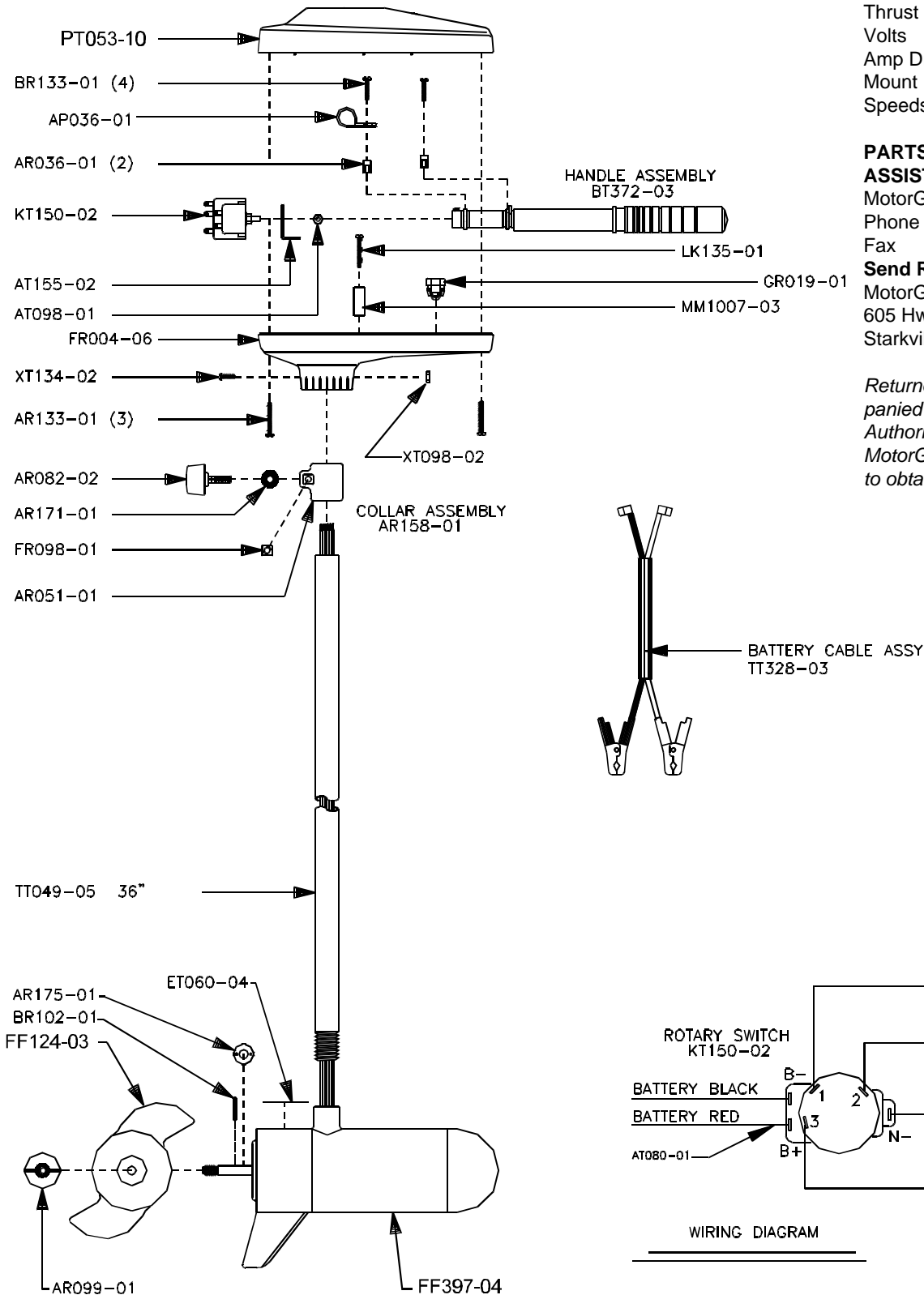

LOWER UNIT BREAKDOWN

Model:
HVT3000

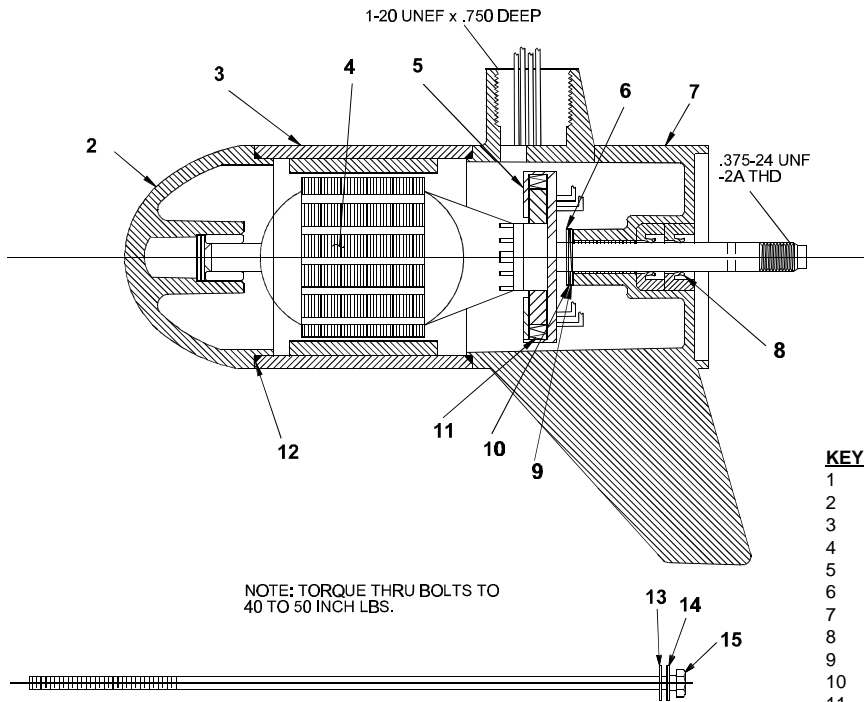

KEY	QTY	DESCRIPTION	PART NO.
1	X	MOTOR	FF397-04
2	1	NOSE CAP	FF3212-01
3	1	HOUSING ASY	FF3210-01
4	1	ARMATURE 3"	FF3207-02
5	1	BRUSH ASY LESS SPRING	FF3201-01
6	1	E RING	MR219-02
7	1	COMM CAP	FF3205-01
8	2	SHAFT SEAL	MR223-01
9	1	NYLATRON WASHER	MR226-01
10	1	WASHER	MR227-01
11	2	BRUSH SPRINGS	MR214-02
12	2	O RING SEAL	HF217-01
13	4	STATIC SEAL	MR223-01
14	4	THRU BOLT WASHER	MR227-01
15	2	THRU BOLT	MR218-05

WIRING

