

MotorGuide® REPAIR PARTS

Model: *Great White*
GWF67V

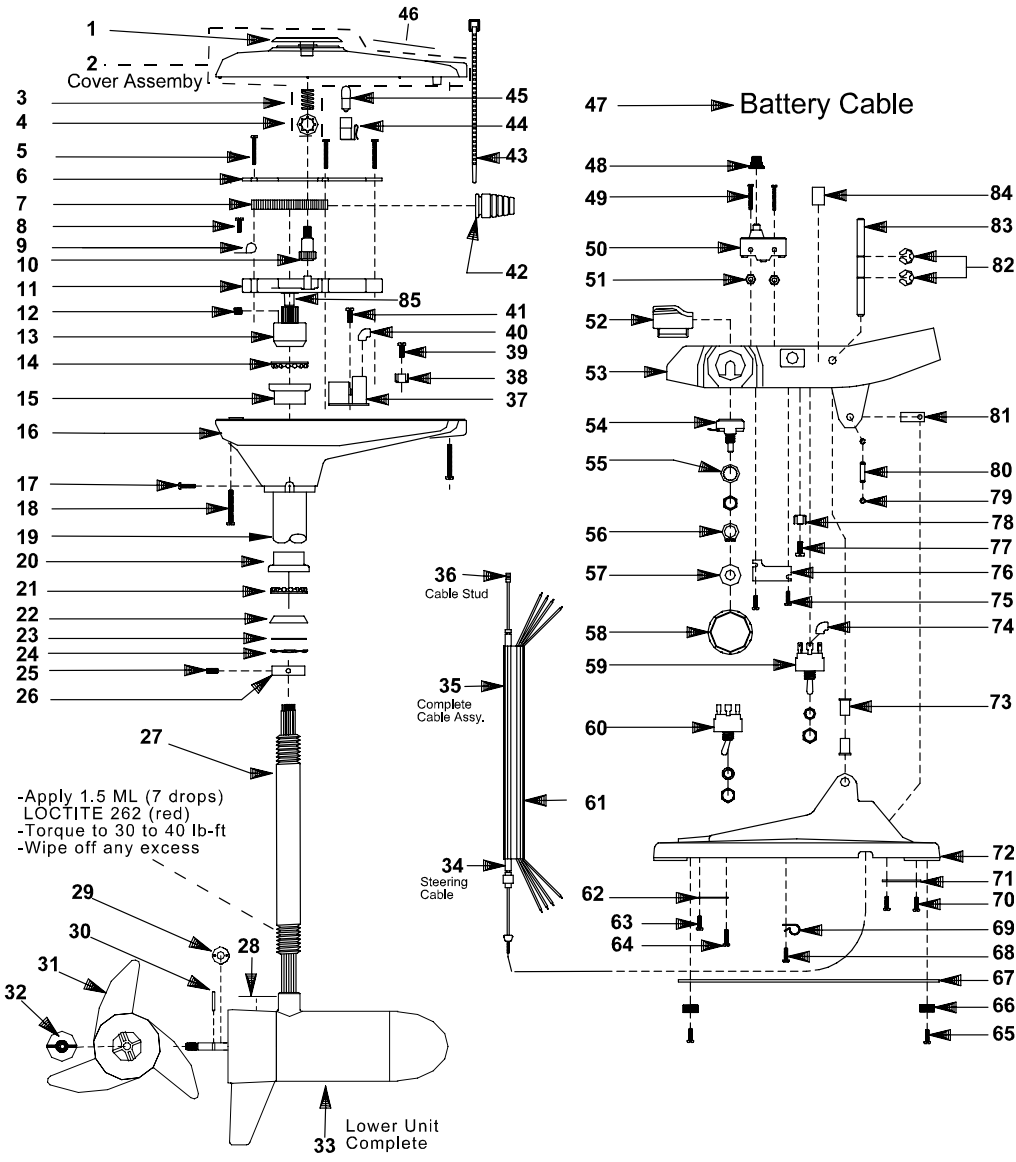

SPECIFICATIONS:

Year of Intro	1998
Thrust	67 LBS
Volts	24VDC
Amp Draw	0 to 33 amps
Mount	20 Bow
Speeds	Variable

QUICK REFERENCE PARTS GUIDE:

Momentary switch	AP151-01
Toggle Switch	FP153-03
DA Board	JF157-02
MOSFET	JF096-08
Motor Seal Kit	6220

PARTS ORDERING & TECH ASSISTANCE

MotorGuide Consumer Relations
 Phone 918-831-6989
 Fax 800-982-8093

Returned Goods must be accompanied with a Returned Goods Authorization. Contact MotorGuide Consumer Relations to obtain RGA.

KEY	DESCRIPTION	PART #	KEY	DESCRIPTION	PART #	KEY	DESCRIPTION	PART #
1	RED INDICATOR	AF078-08	29	MONOFILAMENT WASHER	AR175-01	57	NYLON WASHER	AK171-02
2	T/H COVER COMPLETE BLACK	AF053-13	30	PROP DRIVE PIN	BR102-01	58	VARIABLE SPEED KNOB	LP082-06
3	T/H COVER COMPLETE WHITE	AF053-12	31	PROP/ 2 BLADE	AF124-07	59	TOGGLE SWITCH 3 POSITIONS	FP153-03
4	COMPRESSION SPRING	AF014-01	32	PROP NUT	AR099-01	60		
5	TINNERMAN CLIP	AF046-01	33	24V F/O MOTOR WR	UF397-03	61	69" ELECTRIC CABLE JACKET	MM9006-03
6	#6 RACK GUIDE SCREW	AF133-01	34	63" CONTROL CABLE STUD ASY	9377	62	63" ELECTRIC CABLE JACKET	MM9006-02
7	RACK GUIDE COVER	AF127-01	35	69" CONTROL CABLE STUD ASY	9767	63	CABLE PLATE	KP123-01
8	RACK	AP125-01	36	63" CONTROL CABLE ASY	AP327-16	64	#6 SELF TAP SCREW	EK135-01
9	#10 x 1/2" SCREW	GR133-01	37	69" CONTROL CABLE ASY	AP327-18	65	6 X 1/2 SCREW	AF135-01
10	CABLE CLAMP	AP036-01	38	CONTROL CABLE STUD	AP141-01	66	6 X 1/2 SCREW	AF135-01
11	INDICATOR GEAR	AF069-01	39	24 VOLT DURA AMP BOARD	JF157-02	67	FOOT PEDAL PAD	KP023-01
12	RACK GUIDE	AF126-01	40	TERMINAL (4 PRONG)	FT160-03	68	WEIGHT PLATE ASY	LP3123-01
13	1/4 NUT SET SCREW	AF142-01	41	#10 x 1/2" SCREW	GR133-01	69	6 X 1/2 SCREW	AF135-01
14	PM PINION NUT	AF398-01	42	INSULATING SLEEVE	AT080-01	70	CABLE CLAMP	KP036-01
15	BEARING	FM005-01	43	SELF TAPPING SCREW	AF141-01	71	SCREW	IR133-01
16	BEARING CUP	AF007-01	44	GROMMET	AP071-01	72	BATTERY CLAMP	KP036-02
17	T/H BASE BLACK	AF004-07	45	CABLE TIE	AF030-01	73	FOOT PEDAL BASE	LP003-01
18	T/H BASE WHITE	AF004-06	46	LAMP HOLDER	AF394-01	74	SHAFT BUSHING	KP021-01
19	#6 SELF TAP SCREW	EK135-01	47	LAMP	AF093-02	75	INSULATING SLEEVE	AT080-01
20	SCREW #8 X 3/4	LF141-03	48	NOMENCLATURE	XF056-10	76	6 X 1/2 SCREW	AF135-01
21	42/50" OUTER TUBE	AF165-06	49	BATTERY CABLE ASY	KP328-06	77	RETAINER PLATE	LP123-03
22	BEARING CUP	FM007-01	50	MICRO SWITCH BOOT	KP157-01	78	#10X1/2 SCREW	GR133-01
23	BEARING	FM005-01	51	#6 32 X 1 1/2 SCREW	LP135-01	79	TERMINAL 4 PRONG	FT160-03
24	BEARING RACE	AF006-03	52	MICRO SWITCH	AP151-01	80	E RING	FP046-01
25	O RING	AF063-01	53	6 - 32 NUT S.S	SP098-02	81	CABLE PIVOT PIN	AP105-01
26	WAVE SPRING WASHER	AF171-01	54	MICRO BUTTON	LP026-01	82	CABLE PIVOT	LP091-01
27	CONE SET SCREW	AF143-01	55	FOOT PEDAL	LP101-03	83	.312 E RING	BK046-02
28	BEARING COLLAR	XF006-01	56	FOOT PEDAL ROCKER PIN	AP168-02	84	FOOT PEDAL ROCKER PIN	LP102-01
	42" .105 SS F/O COLUMN	AF049-09		LOCK WASHER 3/8	KP171-01	85	HI BYPASS DECAL	LP057-03
	LOWER UNIT DECAL	ET060-04		GRIP RING	LP046-01		PINION NUT BUSHING	AF021-01

LOWER UNIT BREAKDOWN

Model:
GWF67V

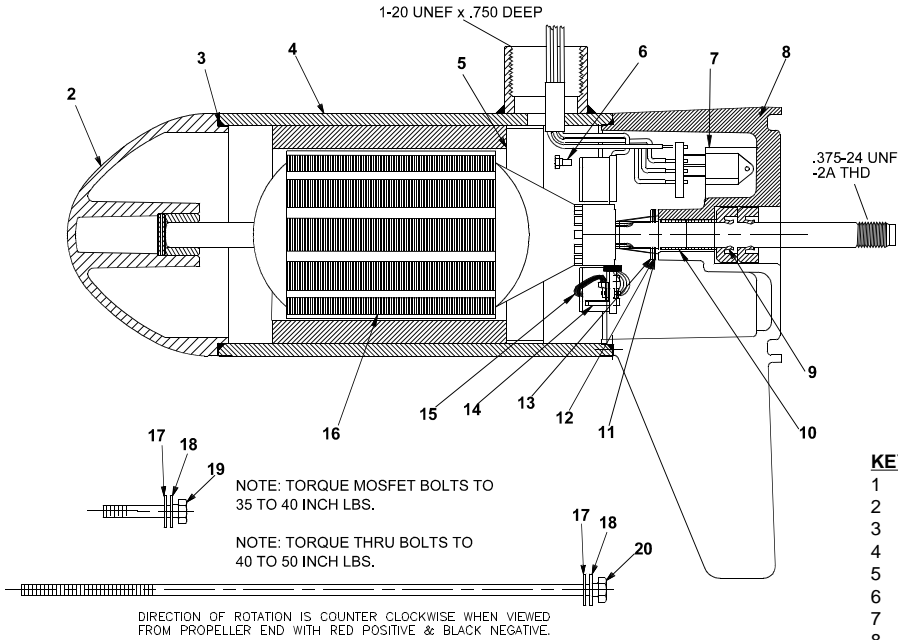

KEY	QTY	DESCRIPTION	PART NO.
1	X	MOTOR	UF397-03
2	1	NOSE CAP	JF3212-02
3	2	O RING SEAL	MR217-01
4	1	HOUSING ASY	UF3210-02
5	1	RETAINER	JF233-01
6	2	BRUSH CARD SCREW	MR228-01
7	1	DURA AMP MODULE	JF096-08
8	1	COMM CAP	UF3205-02
9	2	SHAFT SEAL	MR223-01
10	1	BEARING	MR206-01
11	1	NYLATRON WASHER	MR226-01
12	1	WASHER	MR227-01
13	1	E RING	MR219-01
14	2	BRUSH SPRINGS	MR214-02
15	1	BRUSH ASY LESS SPRING	JF3201-05
16	1	ARMATURE	UF3207-01
17	4	STATIC SEAL	MR222-01
18	4	THRU BOLT WASHER	MR216-02
19	2	DURA AMP SCREW	MR229-02
20	2	THRU BOLT	MR218-03

WIRING

SUBJECT TO DAMAGE BY STATIC ELECTRICITY ASSEMBLE AT STATIC FREE WORK STATION!

SUBJECT TO DAMAGE BY STATIC ELECTRICITY ASSEMBLE AT STATIC FREE WORK STATION!

