

MotorGuide® REPAIR PARTS

Models: 

GWB43 GWT43

SPECIFICATIONS:

Year of Intro	1998
Thrust	43LBS
Volts	12VDC
Amp Draw	0 to 48 amps
Mount	09 Transom
	15 Bow
Speeds	5/2

QUICK REFERENCE PARTS GUIDE:

Handle Asy	BT372-08
Motor Seal Kit	6220
Rotary Switch	KT150-02

PARTS ORDERING & TECH ASSISTANCE

MotorGuide Consumer Relations
Phone 918-831-6989
Fax 800-982-8093

Returned Goods must be accompanied with a Returned Goods Authorization. Contact MotorGuide Consumer Relations to obtain RGA.

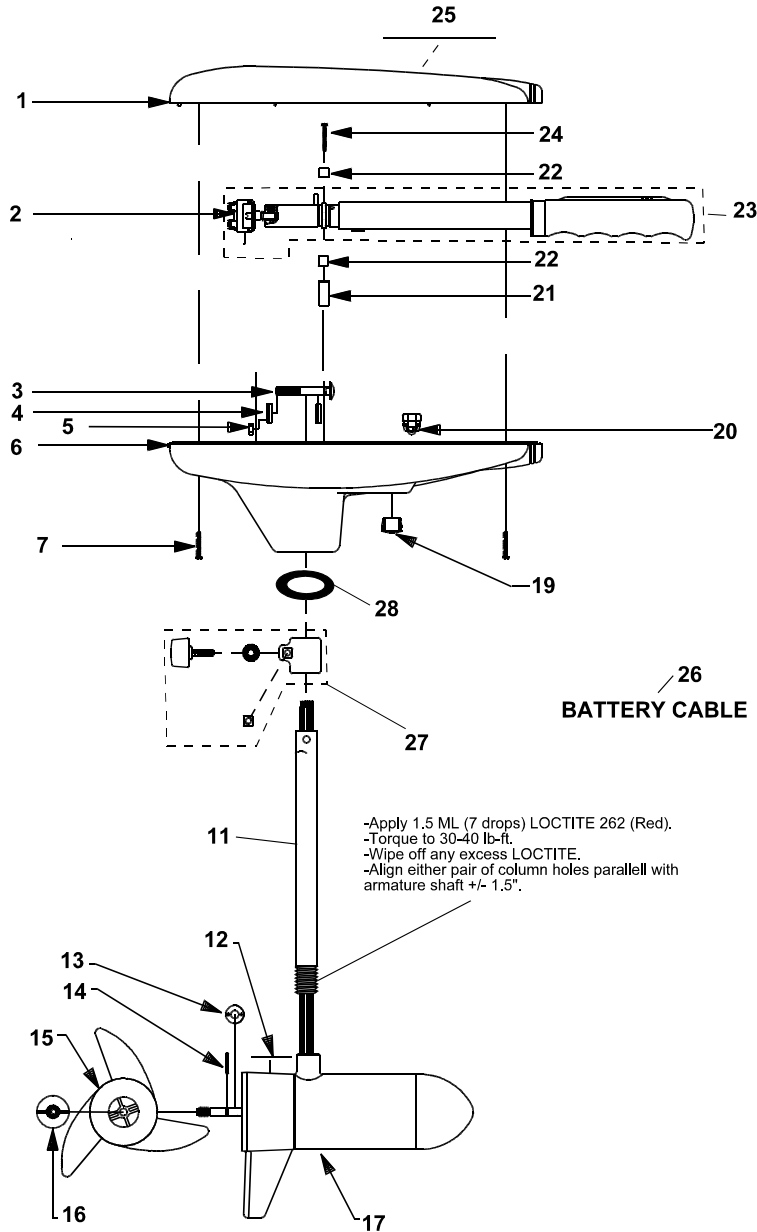

KEY	DESCRIPTION	PART #	KEY	DESCRIPTION	PART #
1	COVER	XT053-35	28	COLUMN SEAL	AT079-01
2	ROTARY SWITCH	KT150-02			
3	BOLT	TT134-02			
4	CURVED WASHER	TT171-08			
5	NYLON LOCK NUT	XT098-02			
6	T/H BASE	AR004-13			
7	SCREW #8 X 1"	XF141-04			
8	BAR KNOB	RT082-02			
9	CLAMP WASHER	RT171-02			
10	SUPPORT NUT	AR098-01			
11	42" .095 SS H/O COLUMN	FR049-15			
12	MARINE LOWER UNIT DECAL	XT060-04			
13	MONOFILAMENT WASHER	AR175-01			
14	PROP DRIVE PIN	BR102-01			
15	PROP/ 3 BLADE	AF124-10			
16	PROP NUT	AR099-01			
17	MOTOR	EF397-06			
18	DEPTH ADJUSTMENT COLLAR	AR051-02			
19	1/2" HOLE PLUG	FP021-03			
20	GROMMET	GR019-03			
21	WIRE BRACKET	AT155-04			
22	RETAINER CLAMP	AR036-01			
23	5 SPEED HANDLE ASY 96-97	BT372-08			
24	8 X 1-3/8 SCREW	RT133-01			
25	NOMENCLATURE GWB43	XT056-29			
	NOMENCLATURE GWT43	XT056-27			
26	BATTERY CABLE	XT328-04			
27	DEPTH COLLAR ASY	XT158-01			

LOWER UNIT BREAKDOWN

Models:
GWB43
GWT43

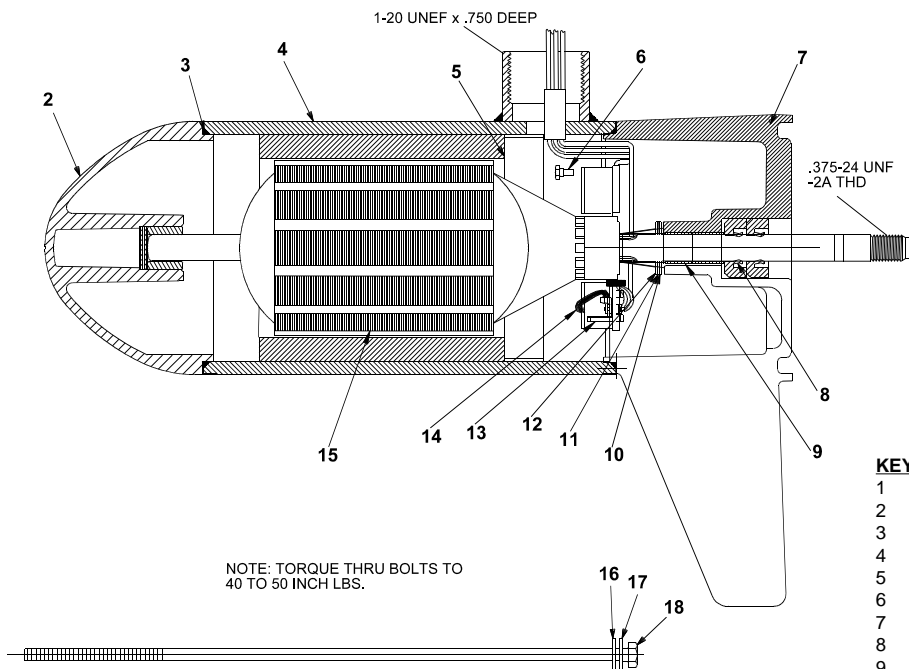

NOTE: TORQUE THRU BOLTS TO 40 TO 50 INCH LBS.

KEY	QTY	DESCRIPTION	PART NO.
1	X	MOTOR	EF397-06
2	1	NOSE CAP	JF3212-02
3	2	O RING SEAL	MR217-01
4	1	HOUSING ASY	KF3210-03
5	1	RETAINER	JF233-01
6	2	BRUSH CARD SCREW	MR228-01
7	1	COMM CAP	EF3205-02
8	2	SHAFT SEAL	MR223-01
9	1	BEARING	MR206-01
10	1	NYLATRON WASHER	MR226-01
11	1	WASHER	MR227-01
12	1	E RING	MR219-01
13	2	BRUSH SPRINGS	MR214-02
14	1	BRUSH ASY LESS SPRING	SM3201-01
15	1	ARMATURE	KF3207-01
16	4	STATIC SEAL	MR222-01
17	4	THRU BOLT WASHER	MR216-01
18	2	THRU BOLT	MR218-07

WIRING

