

MotorGuide® REPAIR PARTS

Model: **Great White**
GWB56

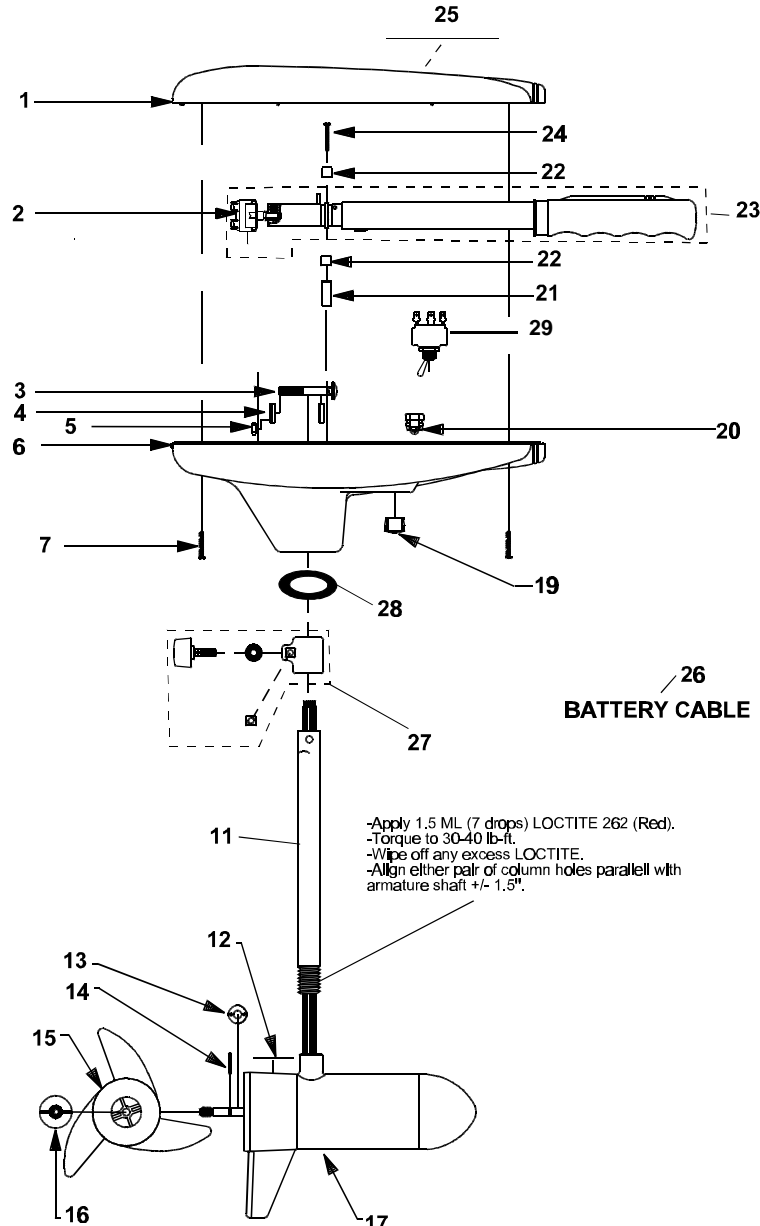

SPECIFICATIONS:

Year of Intro 1998
 Thrust 56LBS
 Volts 12/24VDC
 Amp Draw 0 to 34 amps
 Mount 20 Bow
 Speeds 10 Fwd/Rev

QUICK REFERENCE PARTS GUIDE:

Handle Asy BT372-06
 Motor Seal Kit 6220
 Rotary Switch KT150-02

PARTS ORDERING & TECH ASSISTANCE

MotorGuide Consumer Relations
 Phone 918-831-6989
 Fax 800-982-8093

Send Returned Goods to:

MotorGuide
 605 Hwy 12 West
 Starkville, MS 39760

Returned Goods must be accompanied with a Returned Goods Authorization. Contact MotorGuide Consumer Relations to obtain RGA.

KEY	DESCRIPTION	PART #		
1	COVER	XT053-35	28	COLUMN SEAL AT079-01
2	ROTARY SWITCH	KT150-02	29	TOGGLE SWITCH FP153-04
3	BOLT	TT134-02		
4	CURVED WASHER	TT171-08		
5	NYLON LOCK NUT	XT098-02		
6	T/H BASE	AR004-13		
7	SCREW #8 X 1"	XF141-04		
8	BAR KNOB	RT082-02		
9	CLAMP WASHER	RT171-02		
10	SUPPORT NUT	AR098-01		
11	42" .095 SS H/O COLUMN	FR049-15		
	45" .095 SS H/O COLUMN	FR049-20		
12	MARINE LOWER UNIT DECAL	XT060-04		
13	MONOFILAMENT WASHER	AR175-01		
14	PROP DRIVE PIN	BR102-01		
15	PROP/ 3 BLADE	AF124-10		
16	PROP NUT	AR099-01		
17	MOTOR	BF397-05		
18	DEPTH ADJUSTMENT COLLAR	AR051-02		
19	1/2" HOLE PLUG	FP021-03		
20	GROMMET	GR019-03		
21	WIRE BRACKET	AT155-04		
22	RETAINER CLAMP	AR036-01		
23	5 SPEED HANDLE ASY 96-97	BT372-06		
24	8 X 1-3/8 SCREW	RT133-01		
25	NOMENCLATURE GWB56	XT056-34		
26	BATTERY CABLE	XT328-05		
27	DEPTH COLLAR ASY	XT158-01		

LOWER UNIT BREAKDOWN

Model:
GWB56

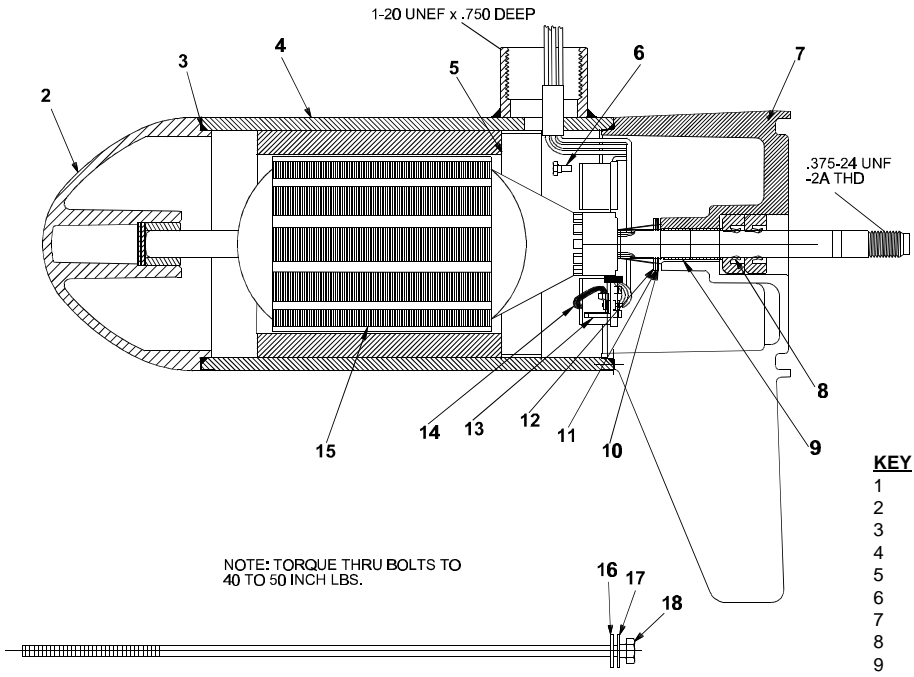

KEY	QTY	DESCRIPTION	PART NO.
1	X	MOTOR	BF397-05
2	1	NOSE CAP	JF3212-02
3	2	O RING SEAL	MR217-01
4	1	HOUSING ASY	JF3210-02
5	1	RETAINER	JF233-01
6	2	BRUSH CARD SCREW	MR228-01
7	1	DURA AMP MODULE	JF096-08
8	1	COMM CAP	UF3205-02
9	2	SHAFT SEAL	MR223-01
10	1	BEARING	MR206-01
11	1	NYLATRON WASHER	MR226-01
12	1	WASHER	MR227-01
13	1	E RING	MR219-01
14	2	BRUSH SPRINGS	MR214-02
15	1	BRUSH ASY LESS SPRING	JF3201-05
16	1	ARMATURE 3.5"	CF3207-01
17	4	STATIC SEAL	MR222-01
18	4	THRU BOLT WASHER	MR216-02
19	2	DURA AMP SCREW	MR229-02
20	2	THRU BOLT	MR218-03

WIRING

