

VANTAGE 74
74 LBS THRUST
24 VOLT

For parts and service
call toll free: 1-888-404-1119
www.mikesreelrepair.com

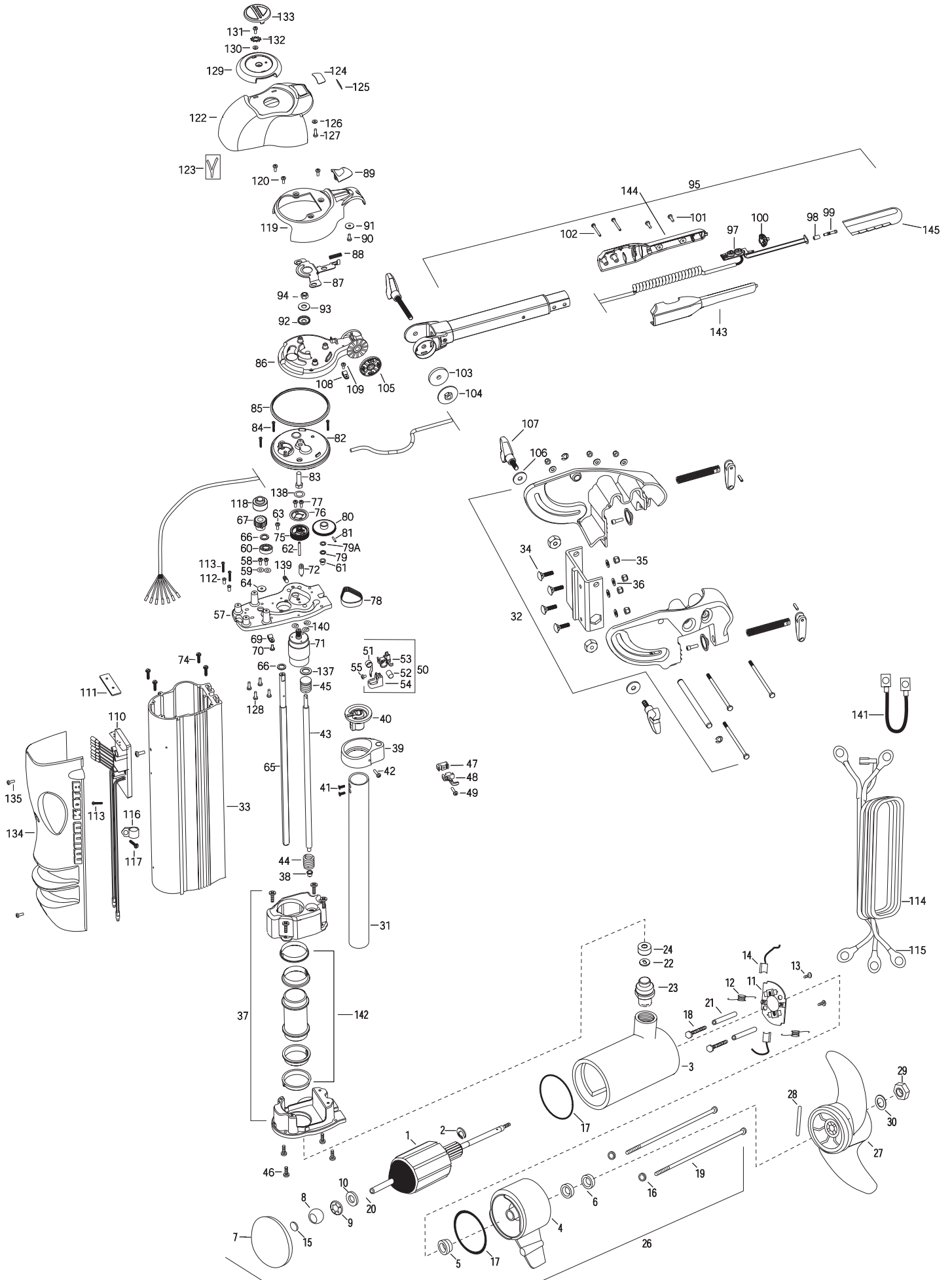

For parts and service
call toll free: 1-888-404-1119
www.mikesreelrepair.com

1	2-100-103	ARMATURE ASSEMBLY 24V 4"	52	2052610	PIN-PIVOT 7/16" O.D.	101	2012100	SCREW-8-18 X 5/8" THD CUT[2.EA]
2	788-040	RETAINING RING	53	2051920	BRACKET-SPRING	102	2053412	SCREW 8 X 1.5"TYPE 25 PPH[2.EA]
3	2-200-160	CENTER HOUSING FIELD ASSEMBLY	54	2052305	WIRE GUIDE (VANTAGE)	■	2880921	HANDLE TENSION KNOB KIT
4	2-300-160	BRUSH END HOUSING ASSEMBLY	55	2053418	SCREW-#4-40X1/4 TYPE F,PPH	*103	2051736	WASHER-URETHN,ID.4 X OD 1
5	144-017	BEARING - FLANGE	■	2770405	TOP PLATE ASSEMBLY	*104	2053115	NUT-WASHER, HANDLE ASSEMBLY
6	880-025	**SEAL [2.EA]	*57	2991907	TOP PLATE/BUSHING ASSEMBLY- VANTAGE	*105	2050015	RACHET-DISK, HANDLE ASSEMBLY
7	2-400-160	PLAIN END HOUSING ASSEMBLY	58	2053414	SCREW-#8-32 X 1/2 TRI-LOBE[2.EA]	■	2880920	BRACKET TENSION HANDLE KIT
8	144-021	BEARING - SPHERICAL	59	2051717	WASHER-#8 SAE FLAT ZNK PLT [2.EA]	*106	2051737	WASHER-FLAT,ID.406 X OD.8
9	784-025	BEARING RETAINER	*60	2057306	BEARING-BALL (VANTAGE)	*107	2050920	HANDLE, TENSION, SHORT
10	991-040	WASHER - FELT	*61	2057302	BEARING-UPPER, LIFT SCREW	108	2052510	CABLE CLAMP, 3/16" VANTAGE[2.EA]
11	2-600-115	BRUSH PLATE ASSEMBLY	*62	2052630	PIN, CLUSTER GEAR	109	2053415	SCREW-#8-32 X 3/8" TRI-LB[3.EA]
12	975-041	SPRING - TORSION [2.EA]	63	2053415	SCREW-#8-32 X 3/8 TRI-LOBE P	*110	2774030	CNTRL BRD ASSY 24/36V W/PAD
13	830-028	SCREW - 10-32 X .164[2.EA]	64	2051716	WASHER-FENDER #10	*111	2315105	INSULATING PAD
14	186-094	BRUSH[2.EA]	65	2052001	SHAFT-STEERING, VANTAGE	112	2261712	SHOULDER WASHER [2.EA]
15	303-043	THRUST DISC - METAL	66	2051706	WASHER-SPRING SUPPORT[2.EA]	113	2053407	SCREW-#8-32 X .75 PPH[3.EA]
16	701-009	**O-RING- THRU BOLT[2.EA]	67	2052205	GEAR, STEERING TUBE MACHINED	114	2053420	SCREW- SET #8-32X1/4 SS
17	701-043	**O-RING[2.EA]	69	2052510	CABLE CLAMP, 3/16" VANTAGE	115	2051220	LEADWIRE,24/36V,3 CONDUCT
18	830-027	SCREW - SELF-THREAD 10-32X2.[2.EA]	70	2053415	SCREW-#8-32 X 3/8 TRI-LOBE P	116	2052512	CABLE CLAMP, 1/2" VANTAGE
19	830-094	THRU BOLT 12-24 X10.31[2.EA]	71	2057800	MOTOR-LIFT (12,24,36V)	117	2053415	SCREW-#8-32 X 3/8" TRI-LOBE P
20	116-025	BALL - STEEL	72	2058411	TENSIONER-BELT (VANTAGE)	118	2052210	ROLLER-STEERING SHAFT
21	973-025	SPACER - BRUSHPLATE[2.EA]	73	831-070	SCREW - TORXW/SPLTWASH[3.EA]	■	2880102	CONTROL HEAD COVER LATCH KIT
22	389-015	GROMMET - STRAIN RELIEF	74	2053413	SCREW-10-16X1" TYPE AB,HEX[4.EA]	119	2050200	COVER-CONTROL HEAD
23	979-015	STRAIN RELIEF - BODY	■	2882201	CLUSTER GEAR / FLANGE PULLEY KIT	120	2053415	SCREW-#8-32 X 3/8" TRI-LOBE [3.EA]
24	979-016	CAP - STRAIN RELIEF	*75	2770428	PULLEY/PINION GEAR ASSEMBLY	121	2012100	SCREW-8-18 X 5/8" THD CUT[3.EA]
26	2317070	MOTOR ASSEMBLY, 4', 24V	*76	2058405	FLANGE-PULLEY (VANTAGE)	122	2050210	SHROUD-CONTROL HEAD
27	2331120	PROPELLER (W.WEDGE) HP&RT	*77	2053411	SCREW 4-40 X 1/4 PPH[2.EA]	123	2055612	DECAL-SHROUD (VANTAGE)[2.EA]
28	2092600	PIN-DRIVE (95-4HP'S)	78	2050800	BELT-DRIVE (VANTAGE)	124	2055600	DECAL-COVER, 24V
29	2383104	NUT- 3/8-24 NYLOC JAM	79	2051705	WASHER-NYLON ID.312 X OD.	125	2055610	DECAL-COVER, LED
30	9950156	WASHER- 3/8 FLAT	79A	2051703	WASHER-THRUST ID.315, OD.562	126	2051712	WASHER- .152 ID, .50 OD, .06
31	2772010	TUBE-MOTOR, 1 3/4" KIT W/TEMPLATE	■	2882200	GEAR LIFT/PIN KIT	*127	2302100	SCREW-6-20 X 1/2" THD CUT
32	2991820	TRANSOM BRACKET ASSEMBLY	*80	2990426	LIFT GEAR ASSEMBLY	128	2012100	SCREW-8-18 X 5/8" THD CUT[4.EA]
33	2056505	HOUSING EXTRUSION	81	2052620	PIN-DRIV-LOK 1/8 X 5/8"	129	2050110	KNOB-POINTER, VANTAGE
34	2053511	BOLT-CARRIAGE 5/16-18 1"[4.EA]	82	2996515	CAP-LOWER, GEAR HOUSING	130	2051717	WASHER- #8 SAE FLAT ZNK PLT
35	2151726	WASHER-5/16 STD (S/S)[4.EA]	83	2383500	BOLT-3/8-16 X 1.25	131	2332101	SCREW-8-32 X 1/2" SS
36	2053103	NUT, 5/16-18 NYLOC [4.EA]	84	2053402	SCREW-10-24 X 1" TRI-LOBE [3.EA]	132	2371715	LOCKWASHER-STAR #8 ZINC
37	2770420	LOWER SUPPORT CAGE ASSEMBLY	85	2054600	O-RING, GEAR HOUSING	133	2056700	PLUG, POINTER, VANTAGE
38	2057302	BEARING-UPPER, LIFT SCREW	86	2056510	CAP-UPPER, GEAR HOUSING	134	2050220	SHIELD-EXTRUSION, VANTAGE
■	2881510	YOKE/BEARING RACE KIT INCL	87	2057200	LATCH (VANTAGE)	135	2053414	SCREW-#8-32 X 1/2" TRI-LOBE[2.EA]
*39	2051510	YOKE-LIFT SCREW	88	2052711	SPRING, LATCH RETURN	136	2055611	DECAL-SHIELD (VANTAGE)[3.EA]
*40	2056200	BEARING RACE-YOKE	89	2050102	KNOB-LATCH (VANTAGE)	137	2151726	WASHER 5/16 STD SS
41	2053401	SCREW-10 X 1/2,TYPE 25,[2.EA]	90	2353401	SCREW-10-16 X 1/2 STALGD	138	2051732	WASHER SS ID.195 OD .278
42	2353401	SCREW-10-16 X 1/2 STALGD	91	2051716	WASHER-FENDER #10	139	2053420	SET SCREW- #8-32X1/4
43	2053400	SCREW-LIFT, 1/2-10 ACME	92	2151730	WASHER-CUP (HINGE BRACKET)	*140	2051710	LOCKWASHER- SPLIT 3MM [3.EA]
44	2052707	SPRING-COIL,SOFT STOP	93	9950156	WASHER-3/8 FLAT (ZINC)	*141	2340610	CONNECTOR CABLE 24V 12"
45	2770429	COIL SPRING/WASHER ASSEMBLY KIT	94	2053107	NUT-3/8-16, TOPLOCK	142	2881500	TUBE/SLEEVE/BUSHING KIT
46	2053413	SCREW-10-16X1" TYPE AB,HEX(4REQ'D)	95	2990950	HANDLE ASSEMBLY, VANTAGE	■	2880910	HANDLE L/R KIT
■	2883200	WIRE CLAMP KIT	■	2884106	HANDLE CTRL BOARD/GRIP KIT			INCL.100,101,102,143,144,145
*47	2053200	WIRE CLAMP, LEFTHAND	*97	2994005	CTRL BOARD ASSEMBLY-HANDLE	*143	2050916	HANDLE SIDE LEFT
*48	2053205	WIRE CLAMP, RIGHTHAND	98	2055115	BUTTON SWITCH ACTUATOR	*144	2050911	HANDLE SIDE RIGHT
*49	2053417	SCREW-10-16X3/4 TYPE BT,PPH	■	2883701	PLUNGER/GRIP KIT	145	2880424	GRIP KIT
50	2770400	TAPE SPRING ASSEMBLY INCL.	*99	2053700	PLUNGER, ON/OFF			
51	2052705	SPRING, CONSTANT FORCE	100	2050111	KNOB-SPEED CONTROL			

**Seal & Oring Kit P/N 2889460

* THIS ITEM IS PART OF AN ASSEMBLY AND CAN NOT BE SOLD SEPARATELY

P/N 2054901 REV.G 4-02

For parts and service
call toll free: 1-888-404-1119
www.mikesreelrepair.com

VANTAGE 74 24V

