

RT55SE
55 LBS THRUST
12 VOLT 50 AMPS
52" SHAFT

for use with "AH" serial numbers
3-year warranty from the date of purchase

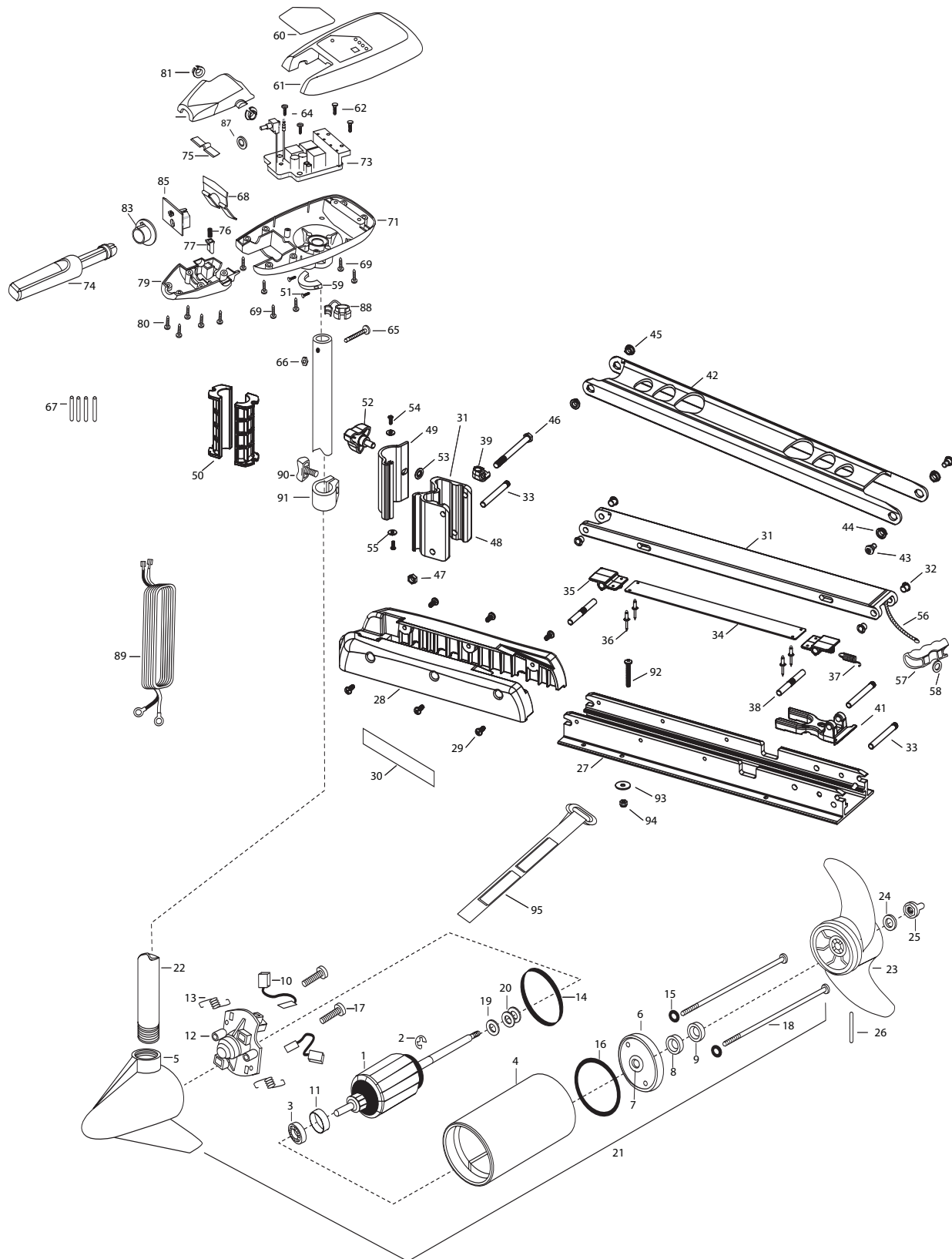

1	2-100-115	ARMATURE ASSEMBLY12V 3.625	32	2266002	NYLINER 3/8" SHAFT [4 EA.]	66	2333101	NUT-HEX 10-24 UNC-2B NYLOC
2	788-015	RETAINING RING	33	2260504	PIVOT PIN, SS [3 EA.]	67	2305401	SHRINK TUBE-3/8 OD X 1-1 [4 EA.]
3	140-010	BEARING -BALL	■	2993811	LATCH STRAP ASSEMBLY, STD	68	2302743	SPRING-DETENT -HANDLE-TILT
4	2-200-301	CENTER HOUSING ASSEMBLY 3.625 WHT	34	2263605	LATCH STRAP, STD	69	2303412	SCREW-6-20 X 5/8 SELF TAP [6. EA]
5	421-336	HOUSING- BRUSH END 3.625 SW WHI	35	2261902	BRACKET-LATCH [2 EA.]	71	2062596	CONTROL BOX, SW, .725 BORE WHT
6	2-400-337	PLAIN END HOUSING ASSEMBLY 3.625	36	2268602	RIVET 1/8" SS [4 EA.]	73	2184000	CONTROL BOARD ASSEMBLY
7	144-049	BEARING - FLANGE [SERVICE ONLY]	37	2262709	SPRING-LATCH PIN	74	2990915	HANDLE ASSEMBLY W/O U-JOINT
8	880-003	SEAL	38	2260502	LATCH PIN, SS [2 EA.]	75	2302742	SPRING-DETENT(OFF) SS
9	880-006	SEAL WITH SHIELD	39	2262310	ROPE GUIDE	76	2302745	SPRING-RELEASE BUTTON SS
10	188-036	BRUSH ASSEMBLY [2. EA]	41	2261544	YOKE-TUBE	77	2303720	RELEASE BUTTON-HANDLE
11	725-050	PAPER TUBE- BRUSH RETENTION	42	2264263	ARM-UPPER, SW, STD	78	2060411	HANDLE (TOP HALF)
12	738-036	BRUSH PLATE W/HOLDER 3.625	43	2263510	BOLT-SHOULDER, SS [2 EA.]	79	2060415	HANDLE (LOWER HALF)
13	975-040	SPRING - TORSION [2.EA]	44	2267302	BUSHING-LOWER 7/16" ID, SS	80	2303412	SCREW-6-20 X 5/8 SELF TAP [5. EA]
14	337-036	GASKET	45	2267303	BUSHING-UPPER 3/8" ID, SS	81	2060005	BEARING-HANDLE PIVOT [2. EA]
15	701-008	O-RING [2. EA]	46	2263506	BOLT 3/8-16 X 4.25", SS	83	2992852	ACTUATOR-CAM
16	701-081	O-RING	47	2263115	NUT-NYLOCK JAM 3/8-16, SS	85	2184020	POT ADAPTER
17	830-007	SCREW # 8-32 [2.EA]	48	2261873	HINGE BASE, SW	87	2181700	WASHER SPACER
18	830-042	THRU BOLT 10-32 X 8.83 [2. EA]	49	2261878	HINGE DOOR, SW	88	2332900	STRAIN RELIEF-C.CORD/SP.C
19	990-067	WASHER - STEEL THRUST	50	2261537	HINGE SLEEVE [2 EA.]	89	2090650	LEADWIRE (10 GA) (RINGS)
20	990-070	WASHER - NYLATRON [2. EA]	51	2263434	SCREW- #8 X 1" PPH SS [2.EA]	90	2011366	SCREW-COLLAR/NEW KNOB (SS)
21	2097095	MOTOR- ASSEMBLY 12V 3.62 SW VARS	52	2260901	HANDLE-SOFT GRIP, L&D, SS	91	2031520	COLLAR-DEPTH (W/O INSERT)
22	2032034	TUBE COMPOSITE 52" WHT	53	2261728	WASHER-RETAINING 3/8"	■	2994938	BAG ASSEMBLY
■	1378131	PROPELLER KIT	54	2332100	SCREW #8-32 X 3/8" TRI, SS [2 EA.]	*92	2263462	SCREW 1/4-20 X 2" PPH [6. EA]
23	2091160	PROPELLER (W.WEDGE 2)	55	2261732	WASHER #8, NYLON [2 EA.]	*93	2261713	WASHER-1/4 FLAT S/S [6. EA]
24	2151726	WASHER- 5/16 STD	56	2251601	ROPE (44.5")	*94	2263103	NUT-1/4-20 NYLOCK-JAM S/S [6. EA]
25	2198400	ANODE-ZINC 3.25/3.625 LWR U	57	2150400	PULL-GRIP	95	2263405	VELCRO STRAP
26	2092600	PIN-DRIVE	58	2151700	WASHER-EYE SHAFT(.562 OD)			
■	2991701	MOUNT,BOW ASSEMBLY,SW STD	59	2061517	COLLAR-CTRL BOX SW WHT			
27	2266503	BOWPLATE, SW, STD, 45"	60	2095681	DECAL-COVER, RT/EDGE 55/B HC			
28	2263906	MOTOR REST, WHITE	61	2300219	COVER- CONTROL BOX RIPTIDE WHT			
29	2332104	SCREW 1/4-20 X 5/8, SS [6 EA.]	62	2301310	SCREW-8-18 X 1/2 SS [2. EA]			
30	2265668	MOTOR REST DECAL, SW [2 EA.]	64	2372100	SCREW-8-18 X 5/8 THD (SS) [2. EA]			
31	2264343	LOWER ARM, SW, STD.	65	2263406	SCREW-10-24 X 2" SS PPH			

Seal & O-Ring Kit p/n 2888460

* This item is part of an assembly. This item cannot be sold separately due to machining and /or assembly that is required p/n 2194944 REV. C 6-06

RT55SE is 12-volt!

