

# QUANTUM E600Ti Energy

## SPECIFICATIONS:

Sodium Freshwater/Light  
 Saltwater  
 65 yds/12 lb. Line Capacity  
 6.2:1 Ratio  
 8.9 oz. Weight  
 5 BB; 1 RB

## FEATURES:

Continuous Anti-Reverse  
 Adjustable Magnetic Anti-  
 Backlash Control with  
 exclusive "Super Free  
 Spool" mode  
 One-piece die-cast  
 aluminum frame  
 Lightweight aluminum spool  
 Brass-alloy Magnum Gears  
 Thumb bar clutch  
 Titanium Line Guide  
 Color: Light Grey

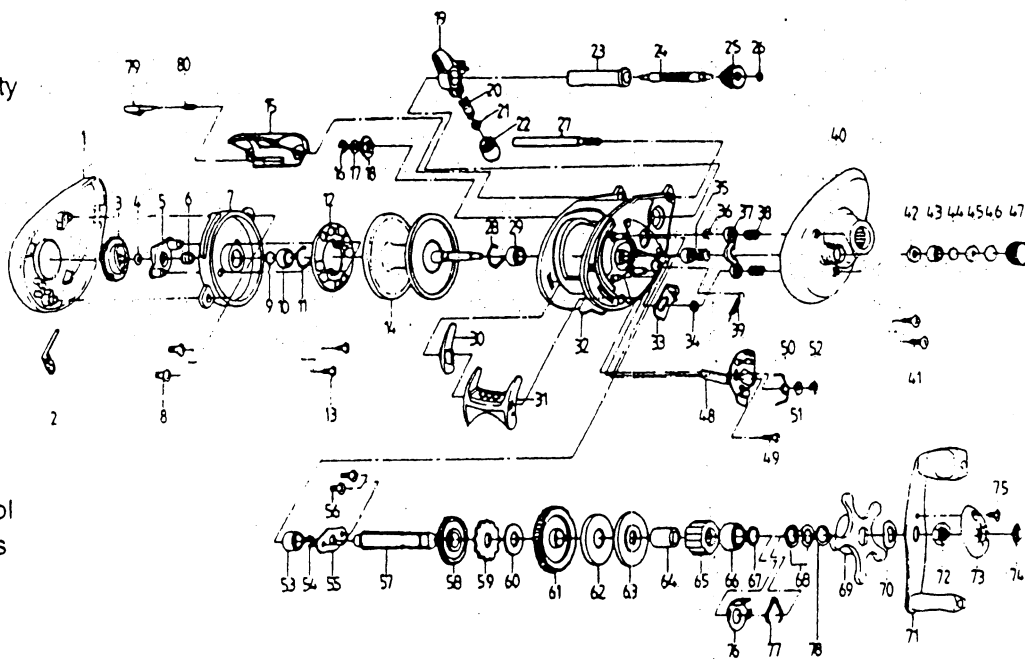

Key No.	Part No.	Description	Price	Key No.	Part No.	Description	Price
	ZW023-03	Left Side Cover	8.95	41	QW123-01	Right Side Cover Screw	.75
	ZW108-01	Clicker	1.00	42	QW101-01	Spool Tension Knob O-Ring	.26
3	ZW026-02	Magnet Dial	1.75	43	SW117-01	Tension Knob Ball Bearing	6.80
4	NX105-01	Dial Friction Ring	.62	44	QW032-04	Spool Tension Washer	.52
5	ZW028-01	Slide Cam	1.20	45	QW081-01	Spool Tension Collar	.96
6	NX071-01	Slide Cam Spring	.52	46	QW082-01	Spool Cushion Washer	.67
7	ZW051-02	Spool Cover (Before H6)	2.80	47	ZW033-02	Spool Tension Knob	5.00
7	ZW051-03B	Spool Cover (After H6)	2.80	48	ZW039-01	Release Slider	3.10
8	ZW125-01	Spool Cover Screw	1.00	49	ZW053-01	Thumb Bar Screw	1.00
9	QW032-03	Spool Tension Shim	.52	50	ZW104-01	Release Slider Spring	1.00
10	SW017-01	Ball Bearing - Spool Shaft (Before H6)	6.80	51	SW121-01	Release Slider Guide Washer	.50
10	UW017-01	Ball Bearing - Spool Shaft (After H6)	6.80	52	NX090-01	Release Slider Guide E-Clip	.41
11	QW080-01	Clip Ring	.52	53	SW017-01	Crank Shaft Lower Bearing	6.80
12	QW330-01	Magnet Plate Assy	2.88	54	QW120-01	Crank Shaft E-Clip	.26
13	QW076-01	Magnet Plate Screw	.67	55	ZW002-01	Crank Shaft Retainer	1.20
14	ZW321-01B	Spool Assy	15.50	56	TW107-01	Crank Shaft Retainer Screw	.10
15	ZW027-03	Front Support	3.50	57	ZW008-01	Crank Shaft	5.60
16	NX092-01	Worm Shaft E-Clip	.30	58	ZW112-01	Oscillate Drive Gear	1.55
17	QW035-03	Worm Shaft Washer	.26	59	QW083-01	Trip Ratchet	.36
18	QW067-01	Worm Shaft Bushing	.67	60	QW111-01	Trip Ratchet Washer	.26
19	ZW347-02	Line Guide Carrier Assy	5.75	61	VW012-01	Drive Gear	10.95
20	ZW006-02	Line Guide Pawl	2.85	62	QW059-01	Drag Disc	1.70
21	QW035-03	Line Guide Pawl Washer	.26	63	QW045-01	Drag "D" Washer	.82
22	ZW007-02	Pawl Cap Screw	2.90	64	CW052-01	One Way Bearing Sleeve	2.88
23	ZW016-01	Worm Shaft Guide	2.00	65	UQ063-02	One Way Bearing	9.27
24	ZW072-01	Worm Shaft	7.20	66	TW058-01	Crank Shaft Ball Bearing	7.21
25	ZW085-01	Oscillate Pinion Gear	1.75	67	TW035-02	Crank Shaft Washer	.46
26	NX090-01	Oscillate Pinion Gear E-Clip	.41	68	QW046-02	Spring "D" Washer	.98
27	ZW061-01	Stabilizer Bar	2.80	69	VW355-01	Star Drag Assy	2.95
28	QW080-01	Clip Ring	.52	70	QW054-01	Handle Washer	.72
29	SW017-02	Ball Bearing - Spool Shaft	6.95	71	ZW318-02	Handle Assy	6.40
30	ZW056-02	Thumb Bar Retainer	.65	72	QW003-03	Handle Nut	1.65
31	ZW309-02	Thumb Bar Assy	1.50	73	ZW034-02	Handle Nut Cap	1.00
32	ZW301-02	Frame Assy	18.50	74	ZW130-02	Line Indicator	1.00
33	ZW077-01	Kick Lever	1.55	75	QW123-05	Handle Nut Cap Screw	.20
34	QW120-01	Pinion Yoke Shaft E-Clip	.26	76	ZW110-01	Drag Click Spring Retainer	1.00
35	VW311-01	Pinion Gear Assy	10.25	77	ZW114-01	Drag Click Spring	1.00
36	QW120-01	Pinion Yoke Shaft E-Clip	.26	78	ZW032-01	Star Drag Washer	1.25
37	ZW025-01	Pinion Yoke	1.00	79	ZW119-02	Side Cover Locking Lever	1.00
38	QW040-01	Pinion Yoke Spring	.67	80	ZW096-01	Locking Lever Spring	1.00
	ZW097-01	Kick Lever Spring	.65				
	ZW024-03	Right Side Cover	9.50				

MODEL INTRODUCED	1995	EFFECTIVE DATE OF PARTS LIST/DIAGRAM	Oct. 1996	DISCONTINUED	N/A
------------------	------	--------------------------------------	-----------	--------------	-----

Prices subject to change without notice. Prices do not include postage and handling.

