

QUANTUM.

E7-1 / E7-1A / E5-1 / E5-1A / E3-1 / E2-1

SPECIFICATIONS :

Light Freshwater
 140 yds / 4 lb Line Capacity
 5.8:1 Gear Ratio
 10.6 oz.
 Bearings: E7-1 - 6 BB; 1 RB
 E5-1 - 4 BB; 1 RB
 E3-1 - 2 BB; 1 RB
 E2-1 - 1 BB; 1 RB

FEATURES :

Front Drag
 Tru-Balanced Rotor
 Balanced Handle
 Twist Reducer Line Roller
 Selective Continuous A/R
 Worm Gear Oscillation
 Spare Alum. Spool (E7-1 / E7-1A)
 Alum. Spool ("A" models w/ holes in skirt)
 Color: E7-1 - Light Silver
 E7-1A - Medium Brown
 E5-1 - Cream
 E5-1A - White
 E3-1 - Dark Grey
 E2-1 - Black

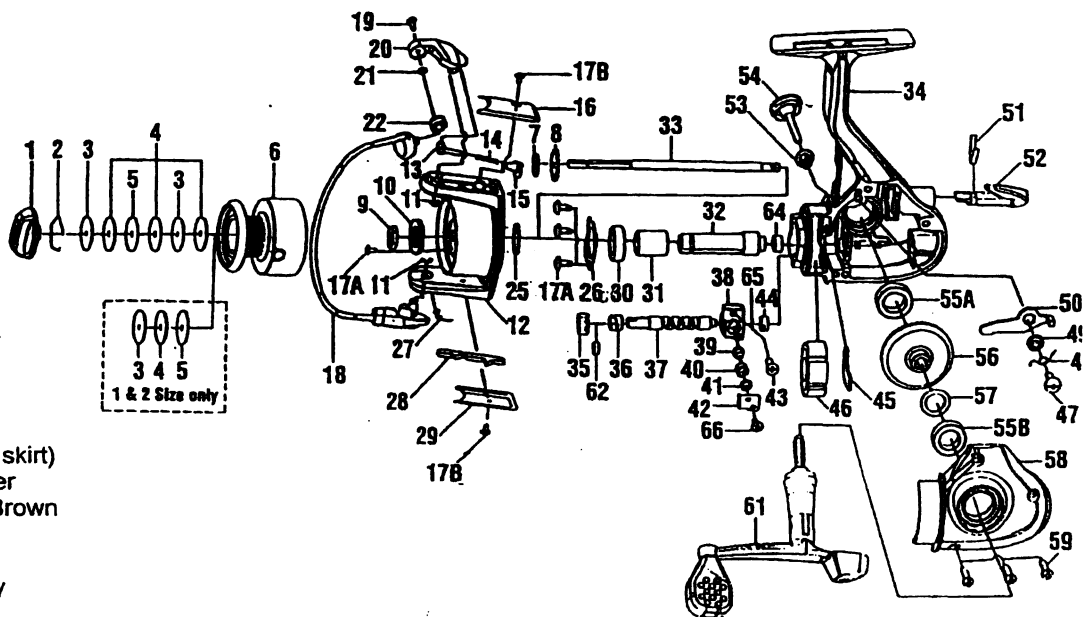

Key No.	E7-1 / A	E5-1 / A	E3-1	E2-1	Description	Price	Key No.	E7-1 / A	E5-1 / A	E3-1	E2-1	Description	Pr
1	FH332-02	FH332-01	FH332-02	FH332-03	Drag Knob	2.97	34	FH301-08	FH301-04	FH301-05	FH301-06	Body Assy.	13
1	FH332-10	FH332-09	N/A	N/A	Drag Knob	2.97	34	FH301-12	FH301-11	N/A	N/A	Body Assy.	13
2	AQ038-01	←	←	←	Drag Retainer	0.32	35	FH200-01	←	←	←	Level Wind Gear	1.
3	TU080-01	←	←	←	Drag Washer "D"	1.16	36	N/A	TU202-01	←	←	Wm Shft Bushing (L)	0.
4	GH033-01	←	←	←	Drag Washer "B"	2.68	36	GH202-01	N/A	N/A	N/A	Wm Shft Bearing (L)	7.
5	TU081-01	←	←	←	Drag Washer "A"	1.16	37	FH201-01	←	←	←	Worm Shaft	2.
6	ZQ321-04	ZQ321-01	ZQ321-02	ZQ321-03	Spool Asy.	7.21	38△	ZQ204-01	←	←	←	Pawl Holder	3.
6	ZQ321-09	←	N/A	N/A	Spool Asy.	7.21	39	TU207-01	←	←	←	Pawl	2.
7	TU030-01	←	←	←	Click Gear Washer	0.96	40	UQ208-03	←	←	←	Pawl Collar	0.
8	TU037-01	←	←	←	Click Gear Washer	1.22	41△	RU209-01	←	←	←	Pawl Washer	0.
9	RU006-01	←	←	←	Rotor Nut	0.93	42△	FH205-01	←	←	←	Pawl Holder Retainer	1.
10	TL065-01	←	←	←	Rotor "D" Washer	1.16	43	UQ100-03	←	←	←	Main Shaft Screw	0.
11	GH034-01	←	←	←	E-Clip	0.32	44	N/A	GH203-01	←	←	Wm Shft Bushing (Rt.)	0.
12	ZQ009-04	ZQ009-01	ZQ009-02	ZQ009-03	Rotor	7.85	44	GH202-02	N/A	N/A	N/A	Wm Shft Bearing (Rt.)	7.
12	ZQ009-11	ZQ009-10	N/A	N/A	Rotor	7.85	45	TU206-01	←	←	←	Worm Shaft Retainer	1.
13	QL031-01	←	←	←	Bail Spring Shaft	0.27	▲46	GH074-01	←	←	←	Clutch Bearing	11
14	KQ049-05	←	←	←	Bail Spring	0.32	46	RU074-01	→→→ Use GH074-01 (clutch bearing) & TU052-01 (bearing sleeve)				
15	QL020-01	←	←	←	Bail Spring Holder	0.32	47	GH077-01	←	←	←	A/R Pawl Screw	0.
16	ZQ087-04	ZQ087-01	ZQ087-02	ZQ087-03	Arm Lvr Spring Cvr	2.67	48	TU061-01	←	←	←	A/R Pawl Spring	0.
16	ZQ087-11	ZQ087-10	N/A	N/A	Arm Lvr Spring Cvr	2.67	49	TU091-01	←	←	←	A/R Pawl Post	1.
17A	UQ057-01	←	←	←	Screw	0.32	50	RU063-01	←	←	←	A/R Pawl	1.
17B	UQ057-03	←	N/A	N/A	Screw	0.32	51	GH089-01	←	←	←	A/R Lever Spring	1.
18	ZQ347-04	ZQ347-01	ZQ347-02	ZQ347-03	Bail Assy.	3.92	52	GH090-03	←	GH090-02	←	A/R Lever	2.
18	ZQ347-12	ZQ347-11	N/A	N/A	Bail Assy.	3.92	52	GH090-05	GH090-04	N/A	N/A	A/R Lever	2.
19	AQ108-01	←	←	←	Line Slider Screw	0.31	53	RU105-01	←	←	←	Handle Cap Washer	0.
20	ZQ007-04	ZQ007-01	ZQ007-02	ZQ007-03	Arm Lever	2.39	54	ZQ073-01	←	←	←	Handle Cap Screw	1.
20	ZQ007-11	ZQ007-10	N/A	N/A	Arm Lever	2.39	55A	BL157-01	←	N/A	N/A	Ball Bearing (Body)	5.
21	GU105-25	←	←	←	Line Roller Washer	0.32	55A	N/A	N/A	GH013-01	←	Bushing (Body)	1.
22	TU004-02	←	N/A	N/A	L/Roller w/Bearing	6.90	55B	BL157-01	←	N/A	N/A	B. Bearing (Body Cvr)	5.
23	N/A	N/A	GH016-01	←	Line Roller Bushing	1.16	55B	N/A	N/A	N/A	GH013-01	Bushing (Body Cover)	1.
24	N/A	N/A	GH004-02	←	Line Roller	4.69	56	FH012-01	←	←	←	Drive Gear	1.
25	GU105-12	←	←	←	Rotor Washer	0.32	57	GU105-13	←	←	←	Adjust Washer	0.
26	N/A	N/A	N/A	N/A	Bearing Plate	—	58	FH023-08	FH023-04	FH023-05	FH023-06	Side Cover	5.
27	GH049-01	←	←	←	Kick Lever Spring	0.32	58	FH023-12	FH023-11	N/A	N/A	Side Cover	5.
28	FH019-01	←	←	←	Kick Lever	1.11	59	KQ057-01	←	←	←	Side Cover Screws	0.
29	ZQ024-04	ZQ024-01	ZQ024-02	ZQ024-03	Kick Lever Cover	2.76	59	KQ057-03	←	N/A	N/A	Side Cover Screws	0.
29	ZQ024-11	ZQ024-10	N/A	N/A	Kick Lever Cover	2.76	61	FH318-03	FH318-01	FH318-02	FH318-03	Handle Assy.	11
30	BL157-01	←	←	←	Pinion Ball Bearing	5.57	61	FH318-06	FH318-05	N/A	N/A	Handle Assy.	11.
▲31	TU052-01	←	←	←	Bearing Sleeve	2.76	62	GH212-01	N/A	N/A	N/A	Worm Shaft Collar	1.
31	RU139-01	→→→ Use TU052-01 (bearing sleeve) & GH074-01 (clutch bearing)					64	RU141-01	←	←	←	Pinion Bushing	1.
32	FH011-01	←	←	←	Pinion Gear	3.55	65	GU105-31	←	←	←	Worm Shaft Washer	0.
33	FH013-01	←	FH013-02	←	Main Shaft	2.60	66	GH123-01	←	←	←	Plate Screw	0.

▲ = Special parts for E7-1A and E5-1A.

△ = Send Key No.'s 38, 41, 42, and 66 if any of these are ordered.

□ = Send Key No.'s 53, 54, and 61 if either part is ordered.

▲ = Both parts must be shipped together if either one is ordered.