

PIRANHA 3 & 4 INSTALL GUIDE

Two components need to be installed on the boat: the transducer and the control head. The control head displays sonar information, the transducer sends and receives sonar signals into the water. Proper installation of each insures best performance of the Piranha and provides the greatest enjoyment and functionality.

Due to the wide variety of boats only general instructions are presented in this installation guide. Each boat has unique characteristics that need to be evaluated.

You will need: Hand drill and various bits, Phillips #2 & 3 drivers, pencil, silicone sealant (for drilled holes), 2-part, slow cure epoxy for inside hull transducer mounting, 12v DC power supply, 1 ampere fuse.

- The mounting area must be in contact with the water when the boat is on plane.
- If the boat is trailered, make sure that the transducer is not inline with trailer bunks or roller assemblies that could damage the transducer during loading operations.

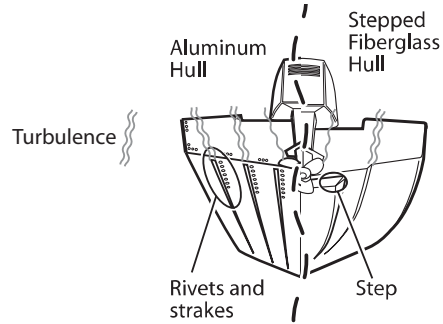

Figure 2, Location of turbulence

INSTALLING THE TRANSDUCER

STEP 1: DETERMINE TRANSDUCER LOCATION

Consider the following to find the best location on the transom: Choose an area free of turbulent water.

- Turbulence is generated as the boat moves through the water and is confined to area aft of ribs, strakes and rivet lines on the bottom of hull. Choose a location on the transom where the hull forward of this location is smooth, flat and free of protrusions or ribs.
- Turbulence is also created by the prop - try to keep at least 380mm (15") from the prop(s).
- The best method to locate areas free of turbulence is to watch the transom while the boat is moving. For best high-speed performance this is recommended. Have an assistant pilot the boat and use caution!
- Stepped hulls require the transducer be mounted on the step if possible. Never mount the transducer on the transom behind the step.
- If propellers are forward of the transom, clear water may be impossible to find. A different transducer or mounting method should be considered, (see optional inside hull instructions below).

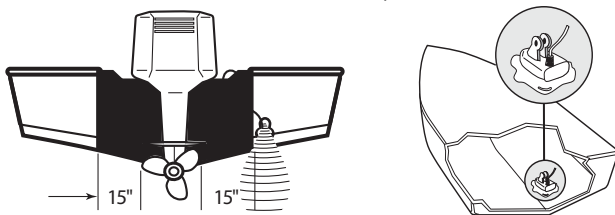

Figure 1. Mounting locations include transom and inside hull.

STEP 2: FOR TRANSMOUNTING: DRILL THE MOUNTING HOLES

1. Remove the mounting template from the last page of Operation Section (Page O-15). This template provides a means of locating the two mounting holes which must be drilled.
2. Hold the template on the transom of the boat in the location where the transducer will be installed. Align the template vertically with the inside arrow of the template on the deadrise where the bottom of the hull meets the transom wall. (Figure 3).
3. Using a pencil or punch, mark the location of the two mounting holes on the transom.
4. Using a 4mm (5/32") bit, drill the two holes to a depth of approximately 25mm (1"). On fiberglass hulls, it is best to start with a smaller bit and use progressively larger drill bits to reduce the chance of chipping or flaking the outer coating.

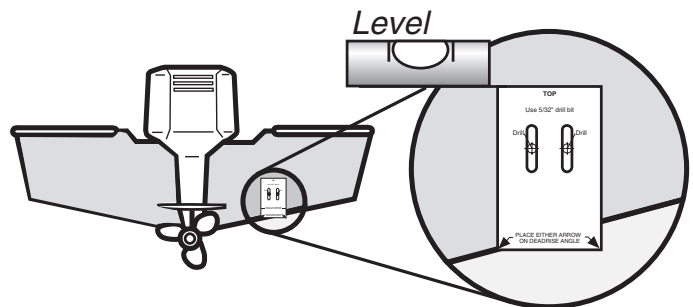

Figure 3

STEP 3: ASSEMBLE & MOUNT THE TRANSDUCER

1. Attach the Transducer Body to the Bracket using the hardware shown below.
2. Tighten the Pivot Bolt just enough so the transducer can rotate, but remain in a place when released.
3. Apply silicone sealant into the drilled mounting holes.
4. Align the transducer with the mounting holes and attach with Phillips screws provided.
5. Tighten the Mounting Screws just enough so the transducer can move vertically, but remain in a place when released.

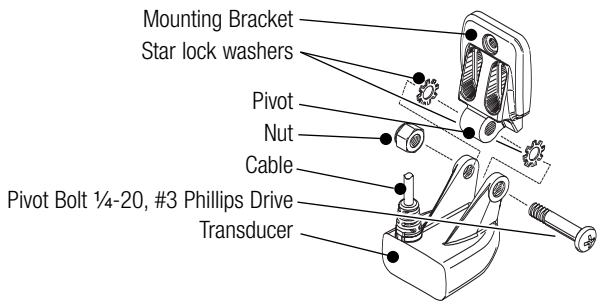

Figure 4

Note: A third mounting screw location is provided in the mounting bracket. Drill and install this ONLY after final testing and adjustments have been made.

STEP 4: ADJUST THE TRANSDUCER

Correct transducer height and running angle settings are needed to ensure best performance at all boat speeds. Use the template provided (pg. O-15) to make the initial setting for most boats. Some boat hulls require adjustments beyond these settings for best performance at all speeds.

1. Cut out the transducer templates from the Piranha package printed template insert following the cutting directions for your boat hull.
2. Adjust the height on the transom and the pivot bolt angle to match guides on the template as shown.
3. Hand tighten the Pivot Bolt and Mount Screws at this time. Ensure the height and angle have not changed.

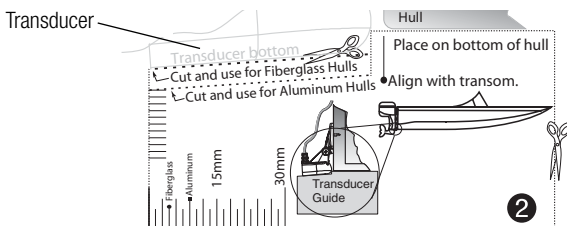

Templates supplied locating the transom bracket and adjusting the transducer's position.

Figure 5

STEP 5: ROUTE THE CABLE

The cable must be routed to where the control head will be mounted. Consider the following:

- The easiest method to get the cable into the boat routes the cable over the transom. The most common method drills a hole through the transom, above the water line.
- Once inside the boat, the cable routes through or along internal conduits and channels.
- Keep the cable as far away as possible from VHF radio antenna and tachometer cables.
- Do not cut, shorten or lengthen the transducer cable.
- If the cable is too short, extensions are available at your dealer or direct from Humminbird.

FOLLOW THESE STEPS:

1. Run the cable over the transom or through a 16mm (5/8") hole drilled well above the water line.
2. If a hole was drilled, fill it with silicone sealant.
3. Secure the cable with clamps as shown. (Figure 6).

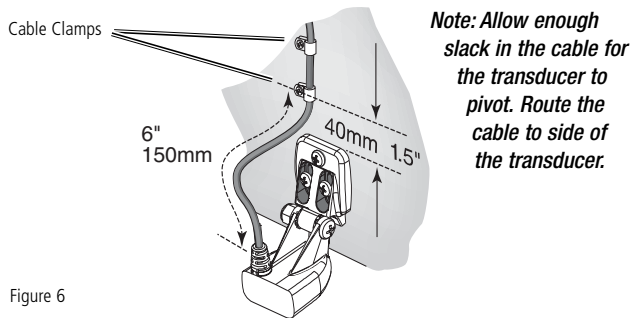

Figure 6

INSTALLING THE CONTROL HEAD

STEP 1: ASSEMBLE THE BASE

1. Insert the Mount Arms through the Base.
2. Secure the Mount Arms with the 4 screws provided.

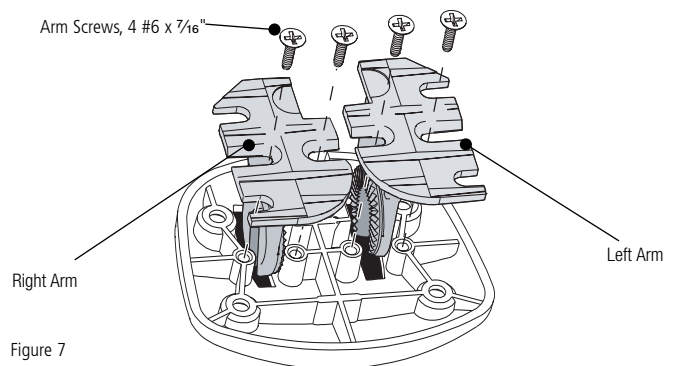
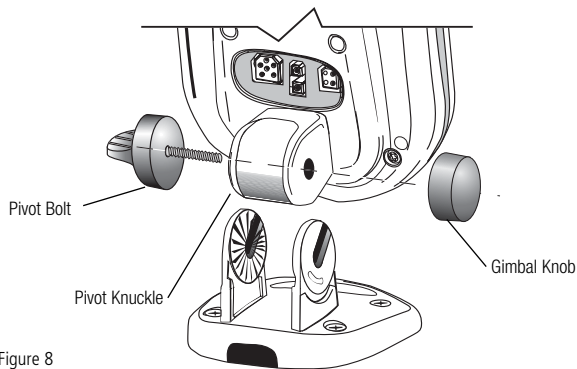

Figure 7

STEP 2: ATTACH THE CONTROL HEAD TO THE BASE

1. Insert the Pivot Bolt through the Pivot Knuckle on the control head.
2. Thread the Gimbal Knob onto the Pivot Bolt using only 2-3 turns.
3. Align the Pivot Knuckle with the Mount Base Arms and slide into place until it seats firmly. A slight twist will aid in seating the unit.
4. Rotate the Control Head to the desired angle and hand tighten the Gimbal Knob.

Now you can use the assembled Piranha to identify the best mounting location.



STEP 3: DETERMINE CONTROL HEAD MOUNTING LOCATION

When choosing a mounting location consider the following:

- Power and transducer cables should be installed first and must reach the control head. Transducer extension cables are available. The power cable can be shortened or lengthened with 18 gauge wire.
- If possible, choose a location that provides access from below so above deck cable length is short, and the cable's hole can be covered by the mount base.

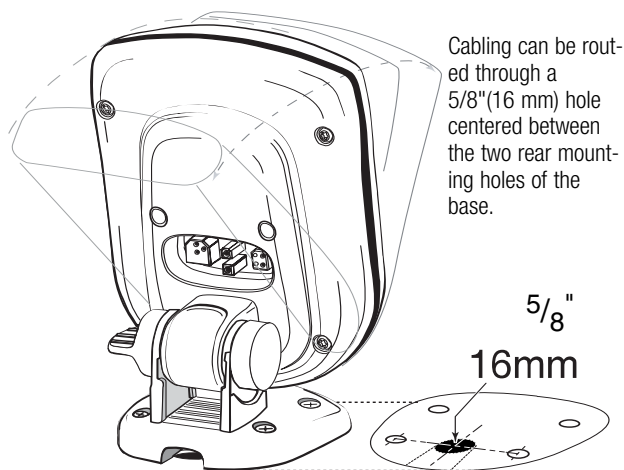

- Ensure enough space exists for easy control head installation and removal and for pivoting through its full range of motion.
- The mounting area should be well supported to protect the fishfinder from wave shock and vibration.
- Choose an area that provides good visibility for the Piranha.

STEP 4: ELECTRICAL CONNECTIONS

A 2m (6') long power cable is included to supply power to the fishfinder. You may shorten or lengthen the cable using 18 gauge multi-stranded copper wire.

CAUTION: Some boats have 24 or 36 volt electric systems. Be sure your unit is connected to a 12 VDC power supply. Humminbird is not responsible for over current or over voltage failures.

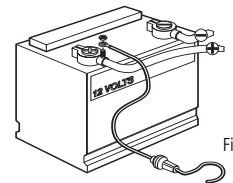
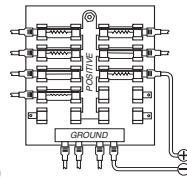

The power cable can be connected to the boat's electrical system at two places: a fuse panel, usually located near the console, or directly to the battery.

If a fuse terminal is available, use crimp-on type electrical connectors (not included) that match the terminal on the fuse panel. Attach the black wire to ground and the red wire to 12 VDC power (Figure 10). Be sure to use a one amp fuse in the connection. If you must wire the control head directly to a battery, be sure to install an inline fuse holder and use a one amp fuse (not included) for the protection of the unit (Figure 11).

In order to minimize the potential for interference with other marine electronics a separate power source (such as a second battery) may be necessary.

STEP 5: INSTALL THE BASE

1. Remove the control head from the mount base by loosening the gimbal knob and pulling the unit from the base - a slight twisting motion will help to release it.
Note: It is not necessary to completely remove the gimbal knob. Unscrew only enough to permit the unit to release.
2. Using the mount base as a template, mark the location for the mounting holes.
3. Drill the mounting holes using a 3.5mm (1/16") bit.

4. Drill a 16mm ($\frac{5}{8}$ ") hole at the location where the cables pass through the mounting surface. If access is possible underneath mounting surface, drill the hole so the mount base forms a hole cover. See Figure 9 for location of cable hole under the mount.
5. Pass the transducer and power cables through the 16mm inch hole, leaving about 150mm length above the surface.
6. Align the mount base with the holes and attach with the Phillips screws provided.

STEP 6: ATTACH THE CONTROL HEAD AND PLUG IN CONNECTORS

1. Mount the control head to the base.
2. With attention to shape and orientation of the plugs, insert the transducer and power cable into the correct socket according to the figure below.

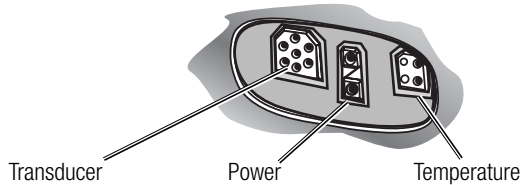

3. With the control head in place, tilt the unit through its full range to ensure enough cable slack is left for movement. Hand tighten the gimbal knob when at its desired position.

YOUR NEW HUMMINBIRD IS NOW READY FOR OPERATION!

TEST & COMPLETE INSTALLATION

Testing should be performed with the boat in the water, however, you can initially confirm basic operation with the boat trailered. Press POWER-MENU once to turn the unit on. An audible chirp sounds any time a button is pressed. If the unit does not power on, ensure the cable plugs are fully seated and there is power available.

The first screen indicates either Start-Up or Simulator. If the unit detects the transducer, Start-Up will be the default selection. If no transducer is detected, Simulator will be selected. Use the Arrow keys to change between Start-Up and Simulator.

Note: The transducer must be submerged in water for reliable transducer detection.

If the transducer is detected, after several seconds the Piranha will begin operation unless you choose another option. If the boat is in the water sonar data begins to scroll across the screen.

If the bottom is visible on-screen with digital depth readout the unit is working properly. If no bottom is visible or erratic operation occurs, ensure that the unit is in water greater than 1 meter (3') and the transducer is fully submerged in water. Remember, sonar signals can not travel through air.

If the unit is working properly, gradually increase boat speed to test higher speed performance. If the unit functions well at low speeds but begins to skip or miss the bottom at higher speeds, the transducer requires adjustment.

Note: Transducer installation often requires several incremental adjustments before optimum high-speed performance is achieved.

To optimize transducer installation, try the following.

- Ensure the transducer is NOT located in an area of turbulent water.
- First, incrementally lower the running depth by 1.5mm ($\frac{1}{16}$ ") until best high-speed performance is achieved.
- If the bracket is fully extended and high-speed performance continues to need adjustment, incrementally change the Pivot Angle to lower the rear of the transducer by 3mm ($\frac{1}{8}$ ") steps until best high-speed performance is achieved.

Important: For transom mount transducers, install the third mounting screw after final transducer adjustments. Hand tighten only!

OPTIONAL INSIDE HULL TRANSDUCER MOUNTING

Inside the hull installation requires the control head to be installed and operational. Inside the hull mounting generally produces good results in single thickness fiberglass-hulled boats.

Note: Transducers with integral temperature sensors will not provide accurate temperature readings when mounting in a hull.

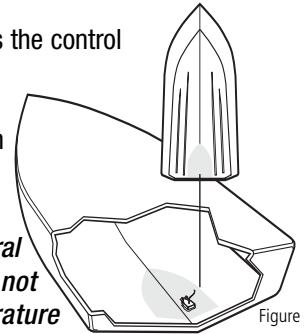

Figure 13

Humminbird cannot guarantee depth performance when transmitting and receiving through the hull of the boat, since some signal loss occurs. The amount of loss depends on hull construction, hull thickness and the installation.

This installation requires slow-cure two-part epoxy. Do not use silicone or any other soft adhesive to install the transducer, as this material reduces the sensitivity of the unit. Five minute epoxy has a tendency to cure before all the air bubbles can be purged.

STEP 1: INSTALL THE CONTROL HEAD

Follow directions above for installing the control head.

STEP 2: DETERMINE THE MOUNTING LOCATION

Begin the transducer installation by determining where inside the hull to install the transducer. Consider the following to find the best location:

- Observe the outside of the boat hull to find the areas that are mostly free from turbulent water. Avoid ribs, strakes and other protrusions as these create turbulence (Figure 2).
- As a general rule, the faster the boat can travel, the further aft and closer to the centerline of the hull the transducer has to be located to remain in contact with the water at high speeds (Figure 13).

STEP 3: TEST THE MOUNTING LOCATION

There is no opportunity for adjustment after the transducer is glued in place. Therefore, it is best to perform a trial installation on inside the hull transducers first, and run the boat at high speeds to determine the best mounting area.

1. At the identified mounting location, lay the transducer body face down with the pointed end towards the bow.
2. Fill the hull with enough water to submerge the transducer body. Use a sand filled bag or other heavy object to hold the transducer in position.

The transducer cannot transmit through air. The water purges any air from between the transducer and the hull, and fills any voids in the coarse fiberglass surface.

3. Power up the Control Head.
4. Run the boat at various speeds and water depths while observing the screen on the Control Head. If the unit functions well at low speeds but begins to skip or miss the bottom at higher speeds, the transducer needs to be moved. If depth performance is required, test the fishfinder in water at the desired depth. Test different locations in the hull until the optimum performance is achieved.

STEP 4: PERMANENTLY MOUNT THE TRANSDUCER

1. Once the mounting location is determined, mark the position of the transducer.
2. Remove the water from inside the hull and thoroughly dry the mounting surface. If the surface is excessively rough, it may be necessary to sand the area to provide a smooth mounting surface.

Make sure the mounting area is clean and dry.

3. Mix an ample quantity of two-part slow-cure epoxy slowly and thoroughly. Avoid trapping air bubbles.

4. Coat the face of the transducer and the inside of the hull.
5. Press the transducer into place with a slight twisting motion to purge any trapped air from underneath, keeping the pointed end of the transducer body pointed forward (Figure 14).
6. Weight the transducer so it does not move while the epoxy is curing.

When the epoxy cures, no water is necessary inside the hull. Neither water, spilled gasoline, nor oil will affect the performance of the transducer.

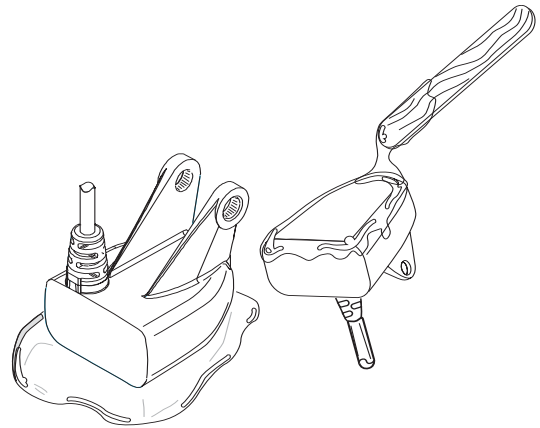

Figure 14