

**MAXXUM 55/H - 42"**  
**55 LBS THRUST**  
**12 VOLT 43 AMPS**  
**42" SHAFT**

For parts and service  
 call toll free: 1-888-404-1119  
 www.mikesreelrepair.com

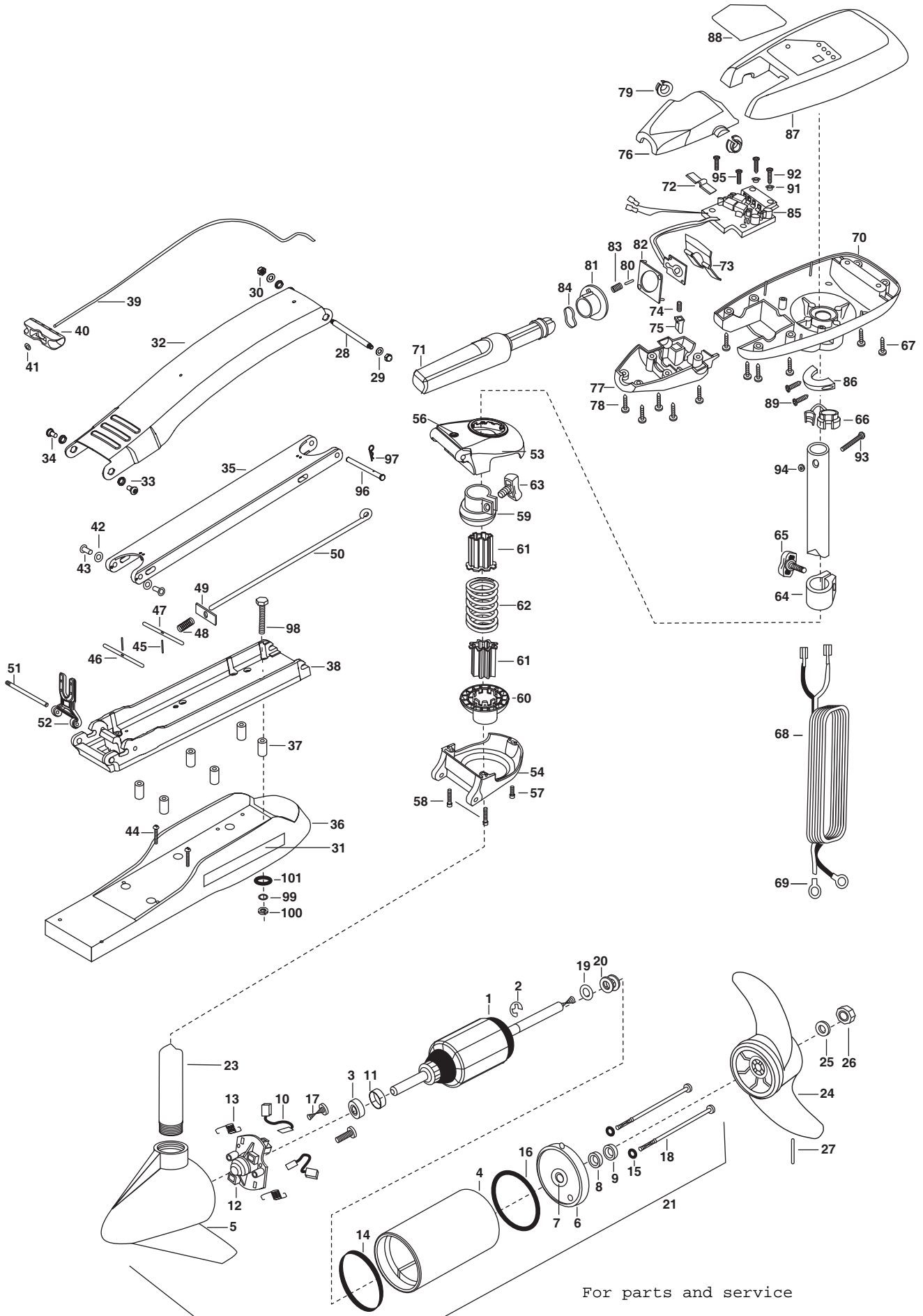

For parts and service  
 call toll free: 1-888-404-1119  
 www.mikesreelrepair.com

1	92-100-013	ARMATURE ASSEMBLY 12V 3.625 FW #55	34	2263500	BOLT, SHOULDER (MAXXUM) [2.EA]	68	2090600	LEADWIRE (10 GA) RINGS
2	788-015	RETAINING RING	35	2774307	ARM-LOWER ASSEMBLY, STD, FW,	69	2020700	TERMINAL RING, 3/8 [2.EA]
3	140-010	BALL BEARING	36	2263912	MOTOR REST MAXXUM	70	2062592	CONTROL BOX,FW, .725 BORE
4	431-101	CENTER HOUSING ASSEMBLY	37	2261505	SPACER, MOTOR REST [6.EA]	71	2990914	HANDLE ASSEMBLY W/O U-JOINT
5	421-065	HOUSING BRUSH END 3.62 TXT	38	2773987	BOWPLATE W/INSERT ASSEMBLY STD FW	72	2302742	SPRING-DETENT (OFF)
6	2-400-101	PLAIN END HOUSING ASSEMBLY	39	2251601	ROPE (40"), MAXXUM MOUNT	73	2302743	SPRING-DETENT (HANDLE-TILT)
7	144-049	BEARING - FLANGE (SERVICE ONLY)	40	2150400	PULL-GRIP	74	2302745	SPRING-RELEASE BUTTON
8	880-003	**SEAL	41	2151700	WASHER-EYE SHAFT (.562 OD)	75	2303720	RELEASE BUTTON-HANDLE
9	880-006	**SEAL WITH SHIELD	42	2261708	WASHER-3/8X1/2X.010 [2.EA]	76	2060409	HANDLE (TOP HALF)
10	188-036	BRUSH ASSEMBLY [2.EA]	43	2236000	BEARING NYLINER- [2.EA]	77	2060415	HANDLE (LOWER HALF)
11	725-050	BRUSH RETENTION- PAPER TUBE	44	2263434	SCREW, 8-18 X 1 PPH SS [2.EA]	78	2303412	SCREW-6-20 X 5/8 SELF TAP [5.EA]
12	738-036	BRUSH PLATE W/HOLDER	45	2152610	SPRING-PIN (LOCKEAR) [2.EA]	79	2060005	BEARING-HANDLE PIVOT [2.EA]
13	975-040	SPRING - TORSION [2.EA]	46	2233600	LOCK BAR- (BOW MOUNT)	80	2302600	PIN-ACTUATOR
14	337-036	**GASKET	47	2233602	LOCK BAR, REAR - ZINC	81	2302850	ACTUATOR-CAM
15	701-008	**O-RING, THRU-BOLT [2.EA]	48	2152700	SPRING-(LOCKBAR) CAD.PLTD	82	2302851	ACTUATOR-FWD/REV
16	701-081	**O-RING	49	2262703	SPRING STOP MAXXUM	83	2302740	SPRING- (ACTUATOR)
17	830-007	SCREW-8-32 [2.EA]	50	2153602	EYE SHAFT-2LOCKBAR STD PLTD	84	2302741	SPRING-CAM (ZNC PLTH STEEL )
18	830-042	THRU-BOLT 10-32X8.83 [2.EA]	51	2260506	HINGE-PIN (HEADLESS) ZINC	85	2334006	CTRL BOARD W/O LEAD 12V
19	990-067	WASHER- STEEL THRUST	52	2293811	YOKE,MAX MNT-POLYPROPYLENE	86	2061515	COLLAR-CTRL BOX (FRS-WTR)
20	990-070	WASHER - NYLATRON [2.EA]	■	2991866	BOWGUARD ASSEMBLY-HAND CTRL	87	2260290	CTRL BOX CVR- BLACK
21	2099094	MOTOR ASSMBLY12V 3.625 VARS 55#	53	2772315	BRKT BASE TOP/EYELET ASSEMBLY	88	2265657	DECAL-COVER MAX 55/HC
23	2032058	TUBE COMPOSITE 42"	54	2991993	BRKT BTM/BEARING FW ASEMBLY	89	2223430	SCREW- #8X3/4 PPH TYPE 25 SS [2.EA]
■	1378122	PROPELLER KIT	56	2772352	EYELET- KIT	91	2301710	WASHER-INSUL.(TRANSF.BAR) [2.EA]
24	2091150	PROPELLER W/WEDGE	57	2263402	SCREW 1/4-20 X 3/4(ZINC)	92	2372100	SCREW-8-18 X 5/8 THD [2.EA]
25	2151726	WASHER- 5/16 SS	58	2263404	SCREW-1/4-20 X 2 1/4 [2.EA]	93	2383407	SCREW-10-24 X 2 PPH ZINC
26	2053101	NUT-PROP NYLOC	59	2261525	SPRING-SLEEVE UPPER	94	2383124	NUT-10-24 NYLOCK
27	2092600	PIN-DRIVE (95-4HP'S)	60	2261535	SPRING SLEEVE, LOWER	95	2301310	SCREW-8-18 X 1/2 [2.EA]
28	2262605	PIN-BWGRDE UPPER THREADED ZP	61	2264702	INSERT-TUBE (2 PER) B.MNT	96	2262607	PIN-CLEVIS ZP MAXXUM BG
29	9908236	WASHER- 1/4 FLAT ZINC [2.EA]	62	2262704	SPRING, BOWGUARD, HAND CT	97	2260801	CLIP- SPRING ZP MAX BG
30	2223100	NUT- TENSION 5/16-18 SS [2.EA]	63	2011365	SCREW-COLLAR/NEW KNOB	■	2994830	BAG ASSEMBLY-MAXXUM INCL. 98-101
31	2265514	DECAL- MAXXUM MOTOR REST [2.EA]	64	2031520	COLLAR-DEPTH (W/O INSERT)	*98	2263431	SCREW 1/4-20 X 3.5 PPH [6.EA]
■	2771866	MOUNT- BOW ASSEMBLY FW STD W/BG	65	2011365	SCREW-COLLAR/NEW KNOB	*99	2261713	WASHER-1/4 FLAT S/S [6.EA]
32	2264241	ARM-UPPER FW,STD	66	2052900	STRAIN RELIEF-C.CORD/SP.C	*100	2263103	NUT-1/4-20 NYLOCK-JAM S/S [6.EA]
33	2293501	BUSHING, STAINLESS STEEL [4.EA]	67	2303412	SCREW-6-20 X 5/8 SELF TAP [6.EA]	*101	2301720	WASHER-MOUNTING*RUBBER [6.EA]

\*\*Seal & Oring Kit P/N 2888460

\* This item is part of an assembly. This item cannot be sold separately due to machining and /or assembly that is required.

P/N 2264958 REV.A 8-01

# MAXXUM 55/H Wiring Diagram

For parts and service

call toll free: 1-888-404-1119

[www.mikesreelrepair.com](http://www.mikesreelrepair.com)

