

**MAXXUM 101/H - 52"**  
**101 LBS THRUST**  
**36 VOLT 37 AMPS**  
**52" SHAFT**

For parts and service  
call toll free: 1-888-404-1119  
[www.mikesreelrepair.com](http://www.mikesreelrepair.com)

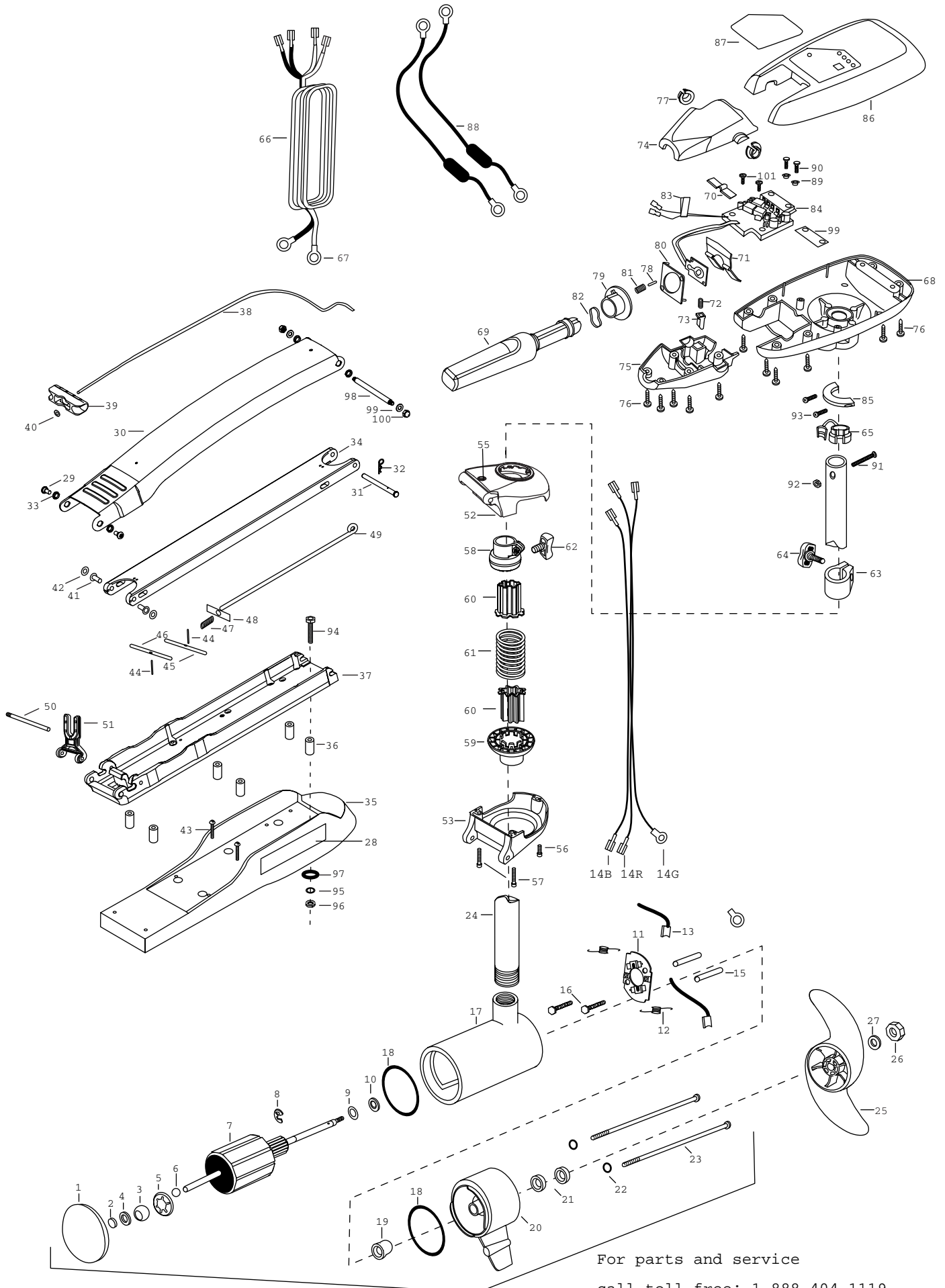

For parts and service  
call toll free: 1-888-404-1119  
[www.mikesreelrepair.com](http://www.mikesreelrepair.com)

1	2-400-160	PLAIN END HOUSING ASSEMBLY	33	2293501	BUSHING, STAINLESS STEEL [4.EA]	68	2062592	CONTROL BOX,FW,.725 BORE
2	303-043	THRUST DISC- METAL	34	2774315	ARM-LOWER ASSEMBLY STD,FW,EXT	69	2990914	HANDLE ASSEMBLY W/O U-JOINT
3	144-021	BEARING -SPHERICAL			INCL 38-40, 44-49	70	2302742	SPRING-DETENT(OFF)
4	991-040	WASHER FELT	35	2263912	MOTOR REST (STD) FW	71	2302743	SPRING-DETENT,HANDLE-TILT
5	784-025	BEARING RETAINER	36	2261505	SPACER, MOTOR REST [6.EA]	72	2302745	SPRING-RELEASE BUTTON
6	116-025	BALL -STEEL	37	2773987	BOWPLATE W/INSERT STD FW	73	2303720	RELEASE BUTTON-HANDLE
7	2-100-110	ARMATURE ASSEMBLY	38	2251601	ROPE (40"), MAXXUM MOUNT	74	2060409	HANDLE (TOP HALF)MAXIMIZE
8	788-040	RETAINING RING	39	2150400	PULL-GRIP	75	2060415	HANDLE (LOWER HALF)
9	990-051	WASHER-THRUST, STEEL	40	2151700	WASHER-EYE SHAFT(.562 OD)	76	2303412	SCREW-6-20 X 5/8 SELF TAP [11.EA]
10	990-052	WASHER- NYLATRON	41	2261708	WASHER-3/8"X1/2"X.010 (S/S) [2.EA]	77	2060005	BEARING-HANDLE PIVOT [2.EA]
11	738-004	BRUSH PLATE -4" TERMINAL	42	2236000	BEARING NYLINER [2.EA]	78	2302600	PIN-ACTUATOR
12	975-041	SPRING -TORSION [2.EA]	43	2263434	SCREW, 8-18 X 1" PPH S/S [2.EA]	79	2302850	ACTUATOR-CAM
13	188-094	BRUSH W/TERMINAL [2.EA]	44	2152610	SPRING-PIN (LOCKBAR) [2.EA]	80	2302851	ACTUATOR-FWD/REV
14B	640-017	BRUSH WIRE-BLK	45	2233600	LOCK BAR-(BOW MOUNT)	81	2302740	SPRING-(ACTUATOR)
14R	640-121	BRUSH WIRE- RED	46	2233602	LOCK BAR, REAR - ZINC	82	2302741	SPRING-CAM(ZNC PLTD STEEL)
14G	640- 303	GROUND WIRE- GREEN	47	2152700	SPRING-(LOCKBAR) CAD.PLTD	83	2305810	TAG-AIR SWITCH LEADS
15	973-025	SPACER -BRUSH PLATE [2.EA]	48	2262703	SPRING STOP MAXXUM	84	2264013	CTRL BOARD ASSEMBLY-RT 101/H
16	830-027	SCREW -SELF TRDED 10-32 X 2" [2.EA]	49	2153602	EYE SHAFT-2LOCKBAR STD SS	85	2061515	COLLAR-CTRL BOX (FRS-WTR)
17	431-110	HOUSING ASSEMBLY- CENTER	50	2260506	HINGE-PIN (HEADLESS)ZINC	86	2260290	CTRL BOX CVR- BLK
18	701-043	**O-RING [2.EA]	51	2293811	YOKE,MAX MNT-POLYPROPYLENE	87	2265622	DECAL-COVER, MAX101/H
19	144-017	BEARING -FLANGE (SERVICE ONLY)	■	2994833	BAG ASSEMBLY MAX STABILIZER KIT	88	2998200	CIRCUIT BREAKER ASSEMBLY36V-101 [2.EA]
20	2-300-160	BRUSH END HOUSING ASSEMBLY	■	2991866	BOWGUARD ASSEMBLY-HAND CTRL	89	2301710	WASHER-INSUL.(TRANSF.BAR) [2.EA]
21	880-025	**SEAL [2.EA]	52	2772315	BRACKET BASE TOP/EYELET ASSEMBLY	90	2372100	SCREW-8-18 X 5/8 THD [2.EA]
22	701-009	**O-RING -THRU BOLT [2.EA]	53	2991993	BRACKET BOTTOM/BEARING ASSEMBLY	91	2383407	SCREW-10-24 X 2." PPH ZINC
23	830-096	THRU BOLT 12-24 X 11.56" SS [2.EA]	55	2772352	EYELET- KIT	92	2383124	NUT-10-24 NYLOCK ZINC PLT
■	2317051	MTR ASSEMBLY 36V 4" VARS [INCL.1-23]	56	2263402	SCREW 1/4-20 X 3/4"(ZINC)	93	2223430	SCREW-#8 X 3/4 PPH TYPE 25 SS [2.EA]
24	2032068	TUBE-CARBON COMPOSITE 52"	57	2263404	SCREW-1/4-20 X 2 1/4 SCHP SS [2.EA]	■	2994830	BAG ASSEMBLY-MAXXUM
■	1378130	PROPELLER KIT INCL. 25-27	58	2261525	SPRING-SLEEVE UPPER	*94	2263431	SCREW 1/4-20 X 3.5 PPH [6.EA]
25	2331130	PROPELLER- W/WEDGE	59	2261535	SPRING SLEEVE, LOWER	*95	2261713	WASHER-1/4 FLAT S/S [6.EA]
26	2093101	NUT-PROP,NYLOC (LARGE) MAX101	60	2264702	INSERT-TUBE (2 PER) B.MNT [2.EA]	*96	2263103	NUT-1/4-20 NYLOCK-JAM S/S [6.EA]
27	2091701	WASHER-PROP (LARGE) MAX 101	61	2262704	SPRING, BOWGUARD, HAND CT	*97	2301720	WASHER-MOUNTING*RUBBER [6.EA]
28	2265514	DECAL- MAX MOTOR REST [2.EA]	62	2011365	SCREW-COLLAR/NEW KNOB	98	2262605	PIN BWGRD UPPER THREADED ZP
■	2771866	MOUNT,BOW ASSEMBLY FW STD	63	2031520	COLLAR-DEPTH (W/O INSERT)	99	9908236	WASHER 1/4 FLAT ZINC [2.EA]
29	2263500	BOLT, SHOULDER (MAXXUM) [2.ea]	64	2011365	SCREW-COLLAR/NEW KNOB	100	2223100	NUT- TENSION 5/16-18 SS [2.EA]
30	2264241	ARM-UPPER FW,STD	65	2052900	STRAIN RELIEF-C.CORD/SP.C	101	2301310	SCREW- #8-18X1/2 SS [2.EA]
31	2262607	PIN- CLEVIS ZP MAX BWGRD	66	2090600	LEADWIRE (10 GA) RINGS			
32	2260801	CLIP-SPRING ZP MAX BWGRD	67	2020700	TERMINAL RING,3/8" [2.EA]			

**\*\*Seal & Oring Kit P/N 2889460**

\* This item is part of an assembly.This item cannot be sold separately due to machining and /or assembly that is required.

P/N 2264930 REV.C 7-01

# MAXXUM 101/H Wiring Diagram

For parts and service  
call toll free: 1-888-404-1119  
[www.mikesreelrepair.com](http://www.mikesreelrepair.com)

