

MAXXUM PRO 101
101 LBS THRUST
36 VOLT 46 AMPS
42" SHAFT

for use with "AH" serial numbers
3-year warranty from the date of purchase

For parts and service
call toll free: 1-888-404-1119
www.mikesreelrepair.com

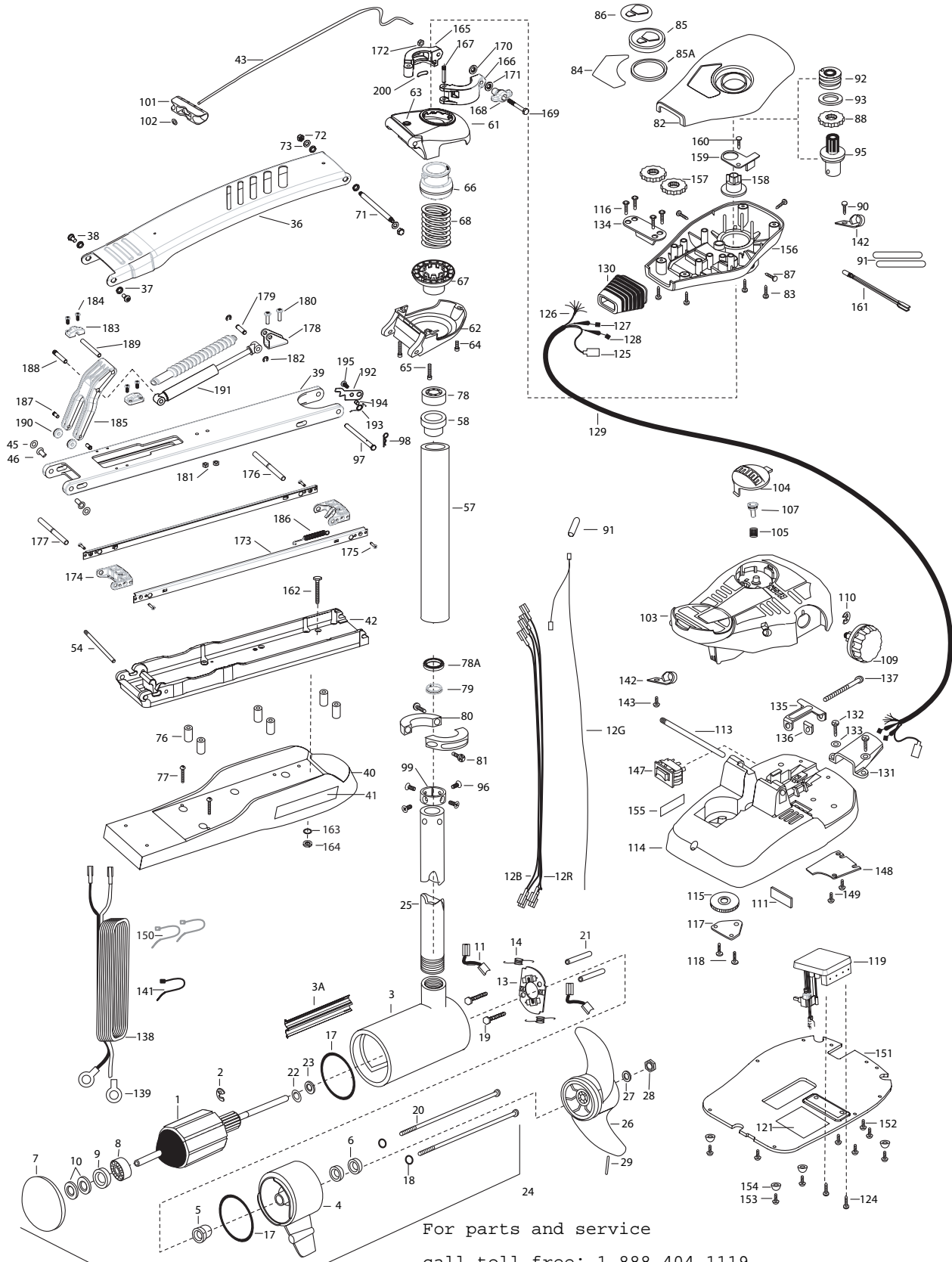

For parts and service
call toll free: 1-888-404-1119
www.mikesreelrepair.com

1	2-100-216	ARMATURE ASSEMBLY 36V 4"	72	2223100	NUT- NYLOC [2.EA]	138	2261233	LEADWIRE VARIABLE
2	788-040	RETAINING RING	73	9908236	WASHER [2.EA]	139	2020700	TERMINAL RING, 3/8 [2.EA]
3	2-200-110	HOUSING ASSEMBLY CENTER 4.0	■	2994832	BAG ASSEMBLY	141	2256300	TIE WRAP-5.5 BLACK
3A	582-014	CLIP, RETAINING, US2	*76	2261505	SPACER, MOTOR REST [6.EA]	142	2263201	CLAMP WIRE HARNESS MICRO [2.EA]
4	2-300-160	BRUSH END HOUSING ASSEMBLY	*77	2263434	SCREW, 8-18 X 1 PPH SS [2.EA]	143	2332103	SCREW-6-20 X 3/8 THD SS
5	144-017	BEARING- FLANGE (SERVICE ONLY)	78	2266000	BEARING, BALL-STEEL	147	2254031	SWITCH-MOM/OFF/COM
6	880-025	SEAL [2.EA]	78A	2266116	BEARING, CARTRIDGE	148	2266412	SWITCH PLATE, PT PEDAL
7	421-276	PLAIN END HOUSING ASSEMBLY	79	2266001	BEARING, SPLIT RING	149	2332103	SCREW-6-20 X 3/8 THD SS [2.EA]
	9421-284	PLAIN END HOUSING ASSEMBLY US2 42"	80	2771617	COLLAR HALF-ZINC-2 PER- KIT	150	2256301	TIE WRAP-5.5 WHITE [2.EA]
8	140-010	BALL BEARING	81	2263452	SCREW-1/4-20 X 3/4 SHCS SS [2.EA]	151	2264511	BOTTOM PLATE, MAXXUM PT
9	990-045	THRUST SPACER	82	2260283	CONTROL BOX COVER-MAXXUM	152	9953104	SCREW-8 X 1/2 PPH SS [5.EA]
10	992-010	SPRING WASHER [2.EA]	83	2372100	SCREW-8-18 X 5/8 THD [4.EA]	153	2263455	SCREW #12 [4.EA]
11	186-094	BRUSH [2.EA]	84	2265642	DECAL COVER, MAXXUM 101	154	2265126	BUMPER [4.EA]
12B	640-014	BRUSH LEAD BLK 10 AWG 51-1/2		2265649	DECAL COVER, MAXXUM 101-SONAR	155	2266610	DECAL-ON/OFF SWITCH
12R	640-118	BRUSH LEAD RED 10 AWG 53		2265693	DECAL COVER, MAXXUM 101-US2	156	2262535	CONTROL BOX-PLASTIC AT'S
12G	640-305	GROUND WIRE 42"	85	2260150	POINTER DISC TRNSLCNT RED	157	2267800	GEAR-INDICATOR [2.EA]
13	738-004	BRUSH PLATE 4"	85A	2261733	WASHER-FOAM, INDICATOR	158	2262220	INDICATOR-DRIVE
14	975-041	SPRING- TORSION [2.EA]	86	2265800	DECAL-INDICATOR	159	2261905	BRACKET/INDICATOR
17	701-043	O-RING [2.EA]	87	2053414	SCREW-#8-32 X 1/2 TRI-LOBE [3.EA]	160	2301310	SCREW-8-18 X 1/2 SS
18	701-009	O-RING —THRU BOLT [2.EA]	88	2267800	GEAR-INDICATOR	161	2264015	LIGHT/INDICATOR
19	830-027	SCREW -SELF THREAD 10-32X2 [2.EA]	90	2301310	SCREW-8-18 X 1/2 SS	■	2994830	BAG ASSEMBLY-MAXXUM
20	830-094	THRU BOLT 12-24X10.31 [2.EA]	91	2355410	SHRINK TUBE-3/8 OD X 2- 3.EA]	*162	2263431	SCREW 1/4-20 X 3.5 PPH [6.EA]
21	973-025	SPACER- BRUSH PLATE [2.EA]	92	2232360	PULLEY-CABLE DRUM	*163	2261713	WASHER-1/4 FLAT S/S [6.EA]
22	990-051	WASHER- STEEL	93	2261730	WASHER-NYLON	*164	2263103	NUT-1/4-20 NYLOCK-JAM [6.EA]
23	990-052	WASHER- NYLATRON	95	2996247	PINION/RACE ASSEMBLY	■	2991550	CLAMP COLLAR ASSEMBLY
24	2316280	MOTOR ASSEMBLY 36V 4" VARS	96	2223468	SCREW-8-32 X 7/16 ZN PL [4.EA]	165	2071550	CLAMP COLLAR "A"
	2326280	MOTOR ASSEMBLY 36V 4" VARS- SONAR	97	2262607	PIN- CLEVIS ZP	166	2071555	CLAMP COLLAR "B"
25	2032003	TUBE COMP W/4 HOLE 42"	98	2260800	SPRING CLIP SS	167	2072621	PIN-KNURLED
■	1378132	PROPELLER KIT	99	2071560	SPLIT COLLAR	168	2070120	KNOB-CLAMP COLLAR
26	2331160	PROPELLER W.WEDGE 2	101	2150400	PULL-GRIP	169	2073412	SCREW 1/4-28 X 2 3/4" SS
27	2091701	WASHER-PROP LARGE	102	2151700	WASHER-EYE SHAFT .562 OD	170	2071718	WASHER #10 NYLON RETAINING
28	2093101	NUT-PROP NYLOCK SS	103	2790002	FOOT PEDAL/PLUG ASSEMBLY	171	2071716	WASHER - FLAT SS
29	2262658	PIN-DRIVE SS	104	2993702	PUSH-BUTTON MAGNET ASSEMBLY	172	2073102	NUT - HEX 1/4 - 28 SS
■	2991740	MOUNT,BOW ASSEMBLY, FW STD W/BG	105	2302732	SPRING-LOWER PEDAL SS	173	2263610	TIE RAIL SHORT [2 EA.]
36	2264250	ARM UPPER-FW STD	107	2260810	CLIP, REED SWITCH	174	2262645	LATCH PIN HOLDER [2 EA.]
37	2293501	BUSHING, STAINLESS STEEL [4.EA]	109	2260160	KNOB-SPEED CONTROL VAR	175	2263456	SCREW #8 - 3/4" BTFH SS [4 EA.]
38	2263500	BOLT, SHOULDER MAXXUM [2.EA]	110	2263000	E-RING TRU-ARC#5133-43	176	2262661	LATCH PIN, GROOVED FRONT SS
■	2774331	LOWER ARM ASSEMBLY,STD,FW,101#	*111	2266413	PLATE -TENSION SCREW FTPED.	177	2262663	LATCH PIN, GROOVED REAR SS
39	2264330	ARM-LOWER ASSEMBLY,STD,FW,EXT	113	2260511	PIN-PIVOT A/T PT PDL	178	2261990	BRACKET, CYLINDER FRONT
40	2263912	MOTOR REST STD MAXXUM	114	2774550	FT PEDAL BASE/PIN ASSEMBLY	179	2262665	PIN, FRONT SHOCK MOUNT
41	2265508	DECAL-MAXXUM,MOTOR REST [2.EA]	115	2262301	PULLEY- FOOT PEDAL	180	2332104	SCREW 1/4-20 X 5/8" PH SS [2 EA.]
42	2773987	BOWPLATE- FW STD MACH/INSERT	116	2223430	SCREW- 8X3/4 PPH TYPE 25 SS [4.EA]	181	2073100	1/4-20" NUT SS [2 EA.]
43	2251601	ROPE 40" MAXXUM MOUNT	117	2266400	COVER-PULLEY STAMPING	182	2263006	E-CLIP 5/16" SHAFT SS [2 EA.]
45	2261708	WASHER-3/8X1/2X.016 [2.EA]	118	2301310	SCREW-8-18 X 1/2 SS [2.EA]	183	2261995	BRACKET- REAR [2 EA.]
46	2267318	BEARING NYLINER- [2.EA]	119	2264054	CONTROL BOARD ASSEMBLY 24V MAX	184	2223454	SCREW #10-32 X 1/2" PH SS [4 EA.]
54	2260506	HINGE-PIN HEADLESS ZINC	121	2365107	INSULATING PAD 2.3 X 3.2	185	2261545	YOKE-GAS ASSIST
■	2772085	TUBE W/BEARING RACE ASSEMBLY 42"	124	2263455	SCREW, 10-32 X 1/2 [2.EA]	186	2262722	SPRING EXTENSION
57	2272085	TUBE -OUTER 21" 4 HOLES [FOR 42"]	125	2211410	EXTENSION CABLE- US2	187	2262635	PIN ROLLER SS [2 EA.]
58	2266260	BEARING RACE-(565T)	126	2261220	WIRE HARNESS AT & MAX 82.5	188	2262667	PIN-KNURLED SS
			127	2267505	CABLE ASSEMBLY-RIGHT 5'	189	2262669	PIN-YOKE PIVOT SS
■	2991763	BOWGUARD ASSEMBLY-FT CTRL,MAX	128	2267515	CABLE ASSEMBLY-LEFT 5'	190	2262320	ROLLER YOKE [2 EA.]
61	2772319	BRACKET BASE TOP/EYELETASSEMBLY	129	2265430	CABLE JACKET 5'	191	2998429	CYLINDER/SHOCK BOOT ASSEMBLY
62	2991770	BRKT BOTTOM/BEARING FW ASSEMBLY	130	2265110	BOOT-CONTROL BOX	192	2262670	LATCH PIN STOP LEVER
63	2262315	EYELET KIT -ROPE	131	2265115	BOOT-FOOT PEDAL BASE	193	2262723	SPRING, MAXXUM PRO
64	2263423	SCREW 5/16-18 X 1 SHCS	132	2372100	SCREW-8-18 X 5/8 THD SS [2.EA]	194	2301700	SPACER-RELEASE LEVER BRASS
65	2263425	SCREW 5/15-18 X 2-1/2 SHCS [2.EA]	133	2261714	WASHER-MAXXUM PT PDL [2.EA]	195	2332104	SCREW 1/4-20 X 5/8" SS
66	2071541	SPRING-SLEEVE UPPER	134	2261901	BRACKET-CONDUIT AT/MAX	200	2075120	URETHANE PAD
67	2071535	SPRING SLEEVE, LOWER	135	2263210	BRACKET-CONDUIT ADJUSTMENT			
68	2262712	SPRING, BOWGUARD, NIK PL	136	2263104	NYLOCK KEEPER			
71	2262605	PIN- THREADED ZP	137	2263463	SCREW-1/4-20 X 2 STL PPH			

Max Pro 101 is 36-volt!

OPTIONAL BROWN WIRE FOR SONAR EQUIPPED MOTORS.
SEE BOAT WIRING DIAGRAM
FIL MARRON OPTIONNEL POUR MOTEURS
ÉQUIPÉS DE SONAR. VOYEZ LE SCHÉMA DE CÂBLAGE DU BATEAU.

SPEED ADJUSTMENT KNOB
MOLETTE DE REGLAGE DE LA VITESSE

For parts and service

call toll free: 1-888-404-1119

www.mikesreelrepair.com

