

**MAXXUM 70**  
**70 lbs Thrust**  
**24 Volt 42 Amp**  
**42" SHAFT**

for use with "AI" serial numbers  
3-year warranty from the date of purchase

For Parts and Service  
Call 1-888-404-1119  
[www.mikesreelrepair.com](http://www.mikesreelrepair.com)

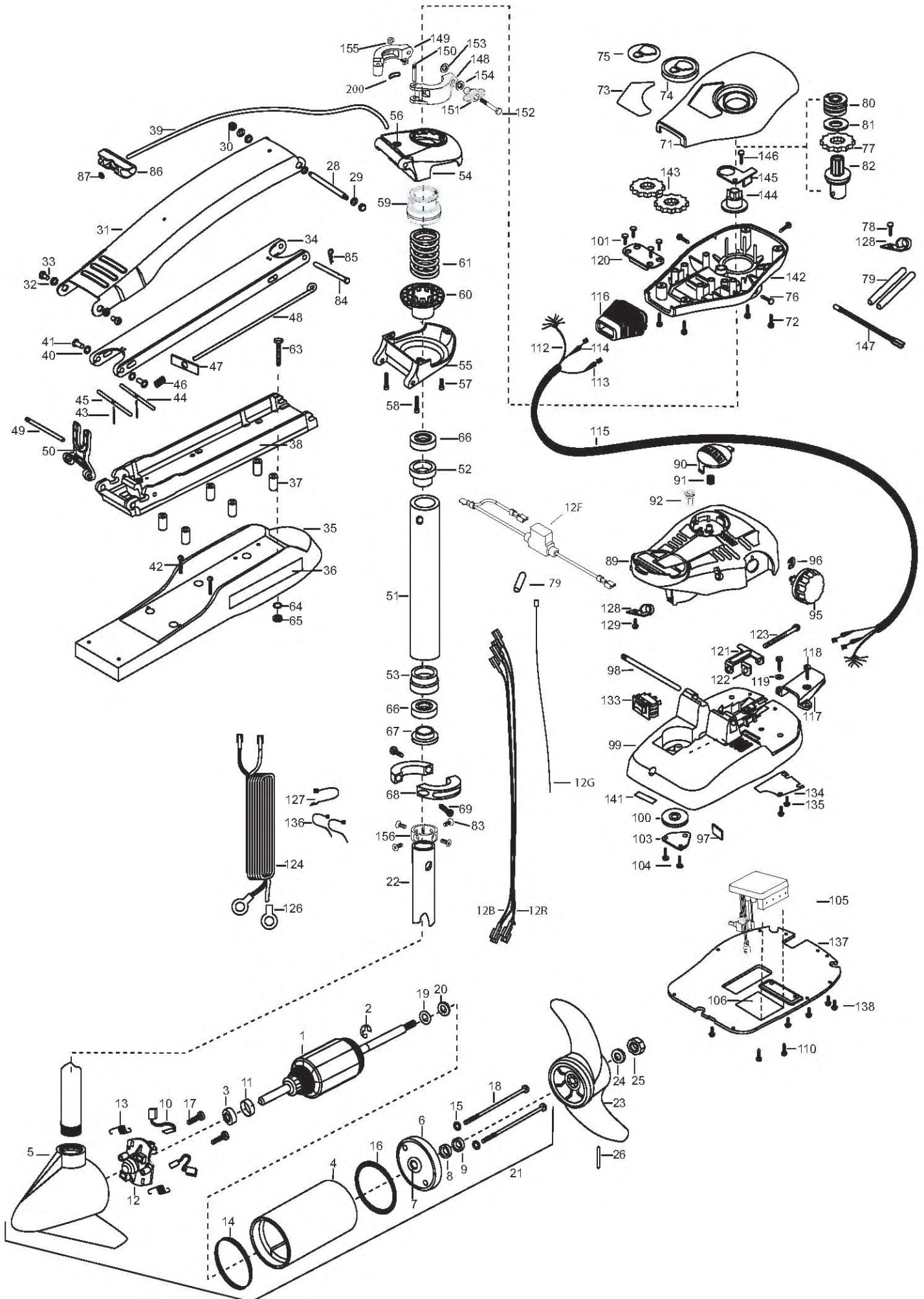

1	2-100-119	ARMATURE ASSEMBLY	47	2262703	SPRING STOP- MAXXUM	101	2223430	SCREW- #8X3/4 PPH TYPE 25 SS [4.EA]
2	788-015	RETAINING RING	48	2153602	EYE SHAFT-2LOCKBAR STD	103	2266400	COVER- PULLEY
3	140-010	BALL BEARING	49	2260506	HINGE-PIN HEADLESS ZINC	104	2301310	SCREW- 8-18 X 1/2 [4.EA]
4	431-005	CENTER HOUSING ASSEMBLY	50	2293811	YOKE- MAKXUM MOUNT,POLYPROPYLENE	105	2264054	CNTROL BOARD ASSEMBLY 24-36V MAX
5	421-065	HOUSING BRUSH END 3.62	■	2772012	TUBE W/BEARING RACE ASSEMBLY	106	2365107	INSULATING PAD (2.3X3.2)
	9421-167	HOUSING BRUSH END 3.62 US2	51	2272069	TUBE OUTER-21" 4 HOLES	110	2223455	SCREW- 10-32 X 1/2" [2.EA]
6	2-400-101	PLAIN END HOUSING ASSEMBLY	52	2266260	BEARING RACE	112	2261220	WIRE HARNESS AT & MAX
7	144-049	BEARING - FLANGE (SERVICE CENTER ONLY)	53	2266220	BEARING RACE- STEEL	113	2267505	CABLE ASSEMBLY- RIGHT (5')
8	880-003	SEAL	■	2991762	BOWGUARD ASSEMBLY- FT CTRL,FW	114	2267515	CABLE ASSEMBLY- LEFT (5')
9	880-006	SEAL WITH SHIELD	54	2772319	BRACKET BASE TOP/ EYELET ASSEMBLY	115	2265430	CABLE JACKET (5')
10	188-036	BRUSH ASSEMBLY [2.EA]	*55	2991771	BRKT BOTTOM/BEARING FW ASSEMBLY	116	2265110	BOOT- CONTROL BOX
11	725-050	BRUSH RETENTION- PAPER TUBE	56	2772352	EYELET- KIT	117	2265115	BOOT- FOOT PEDAL BASE
12	738-036	BRUSH PLATE W/HOLDER	57	2263423	SCREW 5/16-18 X 1" SHCS ZINC	118	2372100	SCREW- 8-18X5/8 THD [2.EA]
12B	640-004	LEADWIRE BLACK 10 GA	58	2263425	SCREW 5/16-18 X 2 1/2" SHCS [2.EA]	119	2261714	WASHER- MAXXUM FT PDL [2.EA]
12R	640-105	LEADWIRE RED 10 GA	59	2071541	SPRING SLEEVE- UPPER	120	2261901	BRACKET- CONDUIT
12G	640-315	GROUND WIRE42" (US MOTORS ONLY)	60	2071535	SPRING SLEEVE- LOWER	121	2263210	BRACKET- CONDUIT ADJUST
12F	2218200	FUSE HOLDER (US MOTORS ONLY)	61	2262712	SPRING- BOWGUARD, NIK PL	122	2263104	NYLOCK KEEPER
13	975-040	SPRING - TORSION [2.EA]	■	2994830	BAG ASSEMBLY- MAXXUM	123	2263463	SCREW- 1/4-20X2" STL PPH
14	337-036	GASKET	*63	2263431	SCREW- 1/4-20 X 3.5 PPH [6.EA]	124	2261233	LEADWIRE- A/T VARIABLE
15	701-008	O-RING, THRU-BOLT [2.EA]	*64	2261713	WASHER- 1/4 FLAT S/S [6.EA]	124A	2060310	FUSED GROUND WIRE
16	701-081	O-RING	*65	2263103	NUT- 1/4-20 NYLOCK-JAM SS [6.EA]	126	2020700	TERMINAL RING- 3/8" [2.EA]
17	830-007	SCREW-8-32 [2.EA]	66	2266000	BEARING BALL- STEEL [2.EA]	127	2256300	TIE WRAP- 5.5" BLACK
18	830-008	THRU-BOLT 10-32X9.2 [2.EA]	*67	2266115	BEARING CONE	128	2263201	CLAMP WIRE HARNESS MICRO [2.EA]
19	990-067	WASHER- STEEL THRUST	*68	2261619	COLLAR HALF- ZINC [2.EA]	129	2332103	SCREW- 6-20X3/8 THD (SS)
20	990-070	WASHER- NYLATRON	*69	2263452	SCREW- 1/4-20X3/4 [2.EA]	133	2254031	SWITCH- MOM/OFF/CON
21	2096030	MOTOR ASSEMBLY 24V F/W	71	2260283	CONTROL BOX COVER- MAXXUM	134	2266412	SWITCH PLATE- FT PEDAL
	2106030	MOTOR ASSEMBLY 24V F/W SONAR	72	2372100	SCREW- 8-18 X 5/8 THD [4.EA]	135	2332103	SCREW- 6-20X3/8 THD SS [2.EA]
22	2032003	TUBE- COMPOSITE W/4 HOLE 42"	73	2265643	DECAL- COVER MAX70/FC	136	2256301	TIE WRAP- 5.5" WHITE [2.EA]
■	1378131	PROPELLER KIT		2265646	DECAL - COVER MAX70/FC SONAR	137	2774511	BOTTOM PLATE- MAXXUM FT
23	2091160	PROPELLER W.WEDGE 2	74	2260150	POINTER DISC TRNSLCNT RED	138	9953104	SCREW-8 X 1/2" (SS) [5.EA]
24	2151726	WASHER-5/16 SS	74A	2261733	WASHER-FOAM, INDICATOR	139	2263455	SCREW- #12-14X1/2 THR FRM [4.EA]
25	2053101	NUT-PROP NYLOC	75	2265800	DECAL- INDICATOR	140	2265126	BUMPER PAD- FOOT PEDAL [4.EA]
26	2092600	PIN-DRIVE	76	2053414	SCREW- 8-32 X 1/2 TRI-LOBE [3. EA]	141	2266610	DECAL- ON/OFF SWITCH
28	2262605	PIN- BWGRD UPPER THREADED ZP	77	2267800	GEAR- INDICATOR	142	2262535	CONTROL BOX- PLASTIC
29	2261722	WASHER- FLAT [2.EA]	78	2372100	SCREW- 8-18 X 5/8	143	2267800	GEAR- INDICATOR [2.EA]
30	2223100	NUT- TENSION 5/16-18 SS [2.EA]	79	2355410	SHRINK TUBE- 3/8 OD X 2" [3.EA]	144	2262220	INDICATOR- DRIVE
■	2991840	MOUNT- ASSEMBLY, W/O BG, STD FW MAX	80	2232360	PULLEY- CABLE DRUM	145	2261905	BRACKET/INDICATOR
31	2264241	ARM-UPPER STD FW	81	2261730	WASHER- NYLON A/T CON	146	2301310	SCREW- 8-18X1/2"
32	2293501	BUSHING- STAINLESS STEEL [4.EA]	82	2996247	TOP BEARING RACE /PINION DRIVE	147	2264015	LIGHT/INDIATOR
33	2263500	BOLT- SHOULDER MAXXUM [2.EA]	83	2223468	SCREW- 8-32 X 7/16 [4.EA]	148	2211410	EXTENSION CABLE- SONAR
34	2774315	ARM-LOWER ASSEMBLY,STD,FW,EXTRA [INCLUDES 39, 43-47, 86,87]	84	2262607	PIN- CLEVIS ZP MAXXUM BWGRD	■	2991556	CLAMP COLLAR ASSEMBLY
			85	2260805	CLIP- SPRING ZP MAX BG	149	2071550	CLAMP COLLAR "A"
35	2263912	MOTOR REST (STD) FW	86	2150400	PULL- GRIP	150	2071555	CLAMP COLLAR "B"
36	2265514	DECAL- MAXXUM MOTOR REST [2.EA]	87	2151700	WASHER- EYE SHAFT(.562 OD)	151	2072621	PIN-KNURLED
37	2261505	SPACER- MOTOR REST [6.EA]	89	2994496	FOOT PEDAL/PLUG ASSEMBLY	152	2281505	KNOB-CLAMP COLLAR
38	2773987	BOWPLATE- W/INSERT	90	2993705	PUSH- BUTTON MAGNET ASSY	154	2071718	WASHER #10 NYLON RETAINING
39	2251601	ROPE (40"), MAXXUM MOUNT	91	2302732	SPRING- LOWER PEDAL	155	2071716	WASHER - FLAT SS
40	2261708	WASHER- 3/8X1/2X.010 SS [2.EA]	92	2260810	CLIP, REED SWITCH	157	2071560	SPLIT COLLAR
41	2267318	BEARING NYLINER [2.EA]	95	2280115	KNOB- SPEED CONTROL (VAR)	158	2263804	STRAP - VELCRO 30.5"
42	2263434	SCREW, 8-18X1" PPH [2.EA]	96	2263000	E-RING THU-ARC	200	2075120	URETHANE PAD
43	2152610	SPRING- PIN LOCKBAR [2.EA]	97	2266413	TENSION SCREW PLATE FTPEDAL			
44	2233600	LOCK BAR- BOW MOUNT	*98	2260511	PIN- PIVOT A/T FT PDL		2888460	seal & oring kit
45	2233602	LOCK BAR REAR - ZINC	99	2774550	FT PEDAL BASE/PIN ASSEMBLY			
46	2152700	SPRING- LOCKBAR CAD.PLTD	100	2262301	PULLEY- FOOT PEDAL			

\* This item is part of an assembly. This item cannot be sold separately due to machining and /or assembly that is required.

For Parts and Service  
 Call 1-888-404-1119  
 www.mikesreelrepair.com

P/N 2274961 REV. N 2-08

**Max 70 is 24-volts only!!!**

OPTIONAL BROWN WIRE FOR SONAR EQUIPPED MOTORS.  
SEE BOAT WIRING DIAGRAM  
FIL MARRON OPTIONNEL POUR MOTEURS  
ÉQUIPÉS DE SONAR. VOYEZ LE SCHÉMA DE CÂBLAGE DU BATEAU.

SPEED ADJUSTMENT KNOB  
MOLETTE DE REGLAGE DE LA VITESSE

For Parts and Service  
Call 1-888-404-1119  
[www.mikesreelrepair.com](http://www.mikesreelrepair.com)

