

MAXXUM PRO 101

101 lbs Thrust
36 volt 46 amps
52" & 62" SHAFT

for use with "J" serial numbers
3-year warranty from the date of sale

For Parts and service
Call 1-888-404-1119
www.mikesreelrepair.com

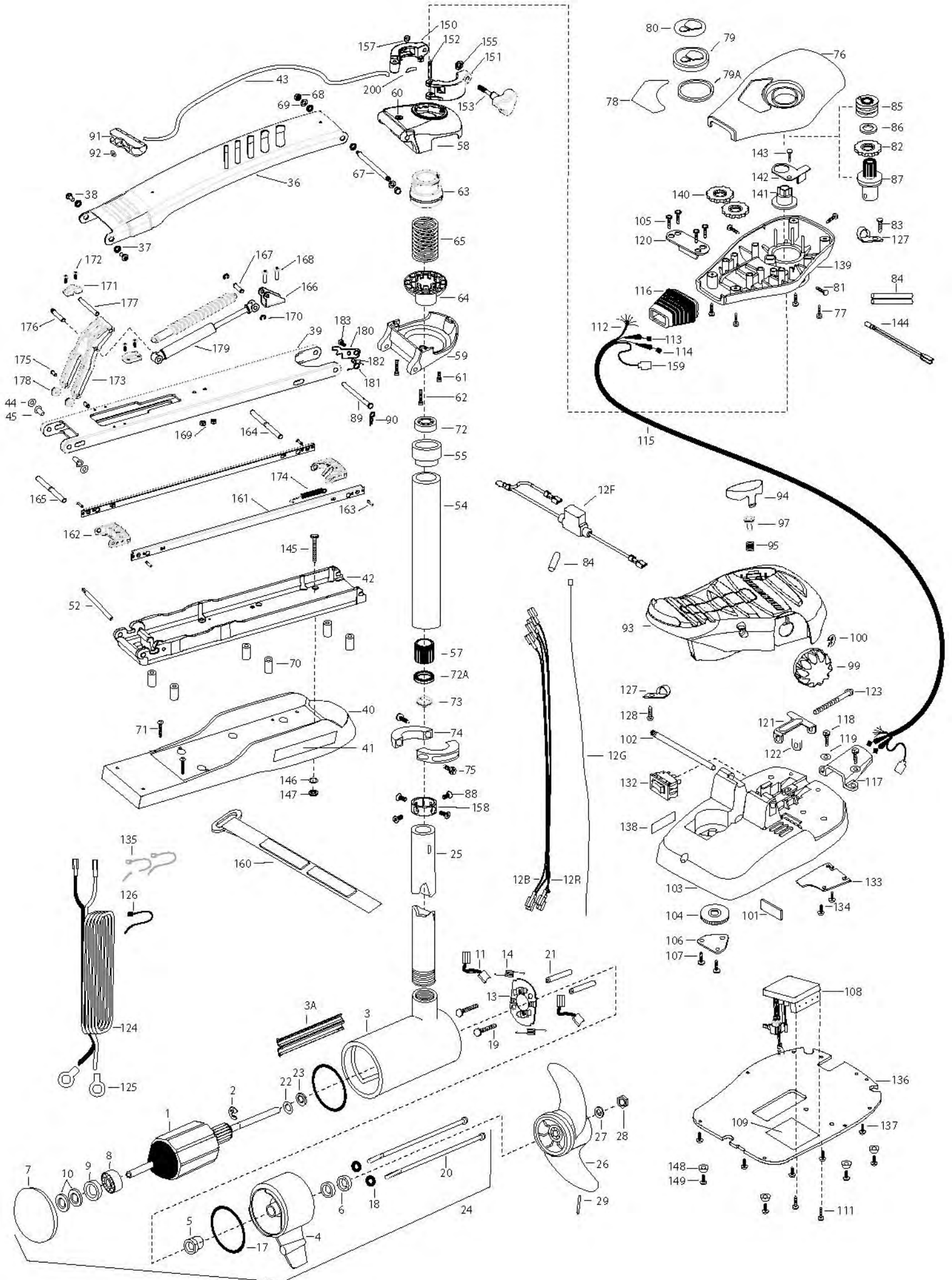

1	2-100-216	ARMATURE ASSEMBLY 36V 4"	58	2772319	BRACKET BASE TOP/EYELET ASSEMBLY	123	2263466	SCREW 1/4-20 X 2 STL PPH
2	788-040	RETAINING RING	59	2991770	BRKT BOTTOM/BEARING FW ASSEMBLY 62	124	2261233	LEADWIRE VARIABLE
3	2-200-110	CENTER HOUSING ASSEMBLY 4.0 TXT	60	2772352	EYELET KIT -ROPE	125	2020700	TERMINAL RING, 3/8 [2.EA]
3A	582-014	CLIP, RETAINING, US2	61	2263423	SCREW 5/16-18 X 1 SHCS	126	2256300	TIE WRAP-5.5 BLACK
4	2-300-160	BRUSH END HOUSING ASSEMBLY	62	2263425	SCREW 5/16-18 X 2-1/2 SHCS [2.EA]	127	2263201	CLAMP WIRE HARNESS MICRO [2.EA]
5	144-017	BEARING- FLANGE (SERVICE ONLY)	63	2071541	SPRING-SLEEVE UPPER	128	2332103	SCREW-6-20 X 3/8 THD SS
6	880-025	SEAL [2.EA]	64	2071535	SPRING SLEEVE, LOWER	132	2254031	SWITCH-MOM/OFF/CON
7	421-276	PLAIN END HOUSING ASSEMBLY	65	2262712	SPRING, BOWGUARD, FC PAINTED	133	2266412	SWITCH PLATE, PT PEDAL
	9421-285	PLAIN END HOUSING ASSEMBLY US2 52"	67	2262605	PIN- THREADED ZP	134	2332103	SCREW-6-20 X 3/8 THD SS [2.EA]
	9421-286	PLAIN END HOUSING ASSEMBLY US2 62"	68	2223100	NUT - NYLOC SS [2.EA]	135	2256301	TIE WRAP-5.5 WHITE [2.EA]
8	140-010	BALL BEARING	69	2261722	WASHER [2.EA]	136	2264511	BOTTOM PLATE, MAXXUM PT
9	990-045	THRUST SPACER	■	2994832	BAG ASSEMBLY	137	2372100	SCREW-8 X 1/2 SS [5.EA]
10	992-010	SPRING WASHER [2.EA]	*70	2261505	SPACER, MOTOR REST [6.EA]	138	2266610	DECAL-ON/OFF SWITCH
11	186-094	BRUSH [2.EA]	*71	2263434	SCREW, 8-18 X 1 PPH SS [2.EA]	139	2262535	CONTROL BOX-PLASTIC
12B	640-024	LEADWIRE-BLACK 10 AWG 79"	72	2266000	BEARING, BALL-STEEL	140	2267800	GEAR-INDICATOR [2.EA]
12R	640-131	LEADWIRE-RED 10 AWG 80 1/2"	72A	2266116	BEARING, CARTRIDGE	141	2262220	INDICATOR-DRIVE
12G	640-316	GROUND WIRE 52" (US MODELS ONLY)	73	2266001	BEARING, SPLIT RING	142	2261905	BRACKET/INDICATOR
	640-317	GROUND WIRE 62" (US MODELS ONLY)	74	2261622	COLLAR HALF-PAINTED-2 PER- KIT	143	2301310	SCREW-8-18 X 1/2 SS
12F	2218200	FUSE HOLDER (US MODELS ONLY)	75	2263453	SCREW-1/4-20 X 3/4 SHCS SS [2.EA]	144	2264015	LIGHT/INDICATOR
13	738-040	BRUSH PLATE 4"	76	2260283	CONTROL BOX COVER-MAXXUM	■	2994830	BAG ASSEMBLY-MAXXUM
14	975-041	SPRING- TORSION [2.EA]	77	2372100	SCREW-8-18 X 5/8 THD [4.EA]	*145	2263431	SCREW 1/4-20 X 3.5 PPH [6.EA]
17	701-009	O-RING —THRU BOLT [2.EA]	78	2265642	DECAL COVER, MAXXUM 101	*146	2261717	WASHER-1/4 FLAT S/S [6.EA]
18	701-043	O-RING [2.EA]		2265649	DECAL COVER, MAXXUM 101-SONAR	*147	2263103	NUT-1/4-20 NYLOCK-JAM [6.EA]
19	830-027	SCREW -SELF THREAD 10-32X2 [2.EA]		2265693	DECAL COVER, MAXXUM 101 US2	148	2265126	BUMPER [4.EA]
20	830-096	THRU BOLT 12-24X10.31 [2.EA]	79	2260150	POINTER DISC TRNSLCNT RED	149	2263455	SCREW #12 [4.EA]
21	973-025	SPACER- BRUSH PLATE [2.EA]	79A	2261733	WASHER-FOAM, INDICATOR	■	2991556	CLAMP COLLAR ASSEMBLY
22	990-051	WASHER- STEEL	80	2265800	DECAL-INDICATOR	150	2071550	CLAMP COLLAR "A"
23	990-052	WASHER- NYLATRON	81	2053414	SCREW-#8-32 X 1/2 TRI-LOBE [3.EA]	151	2071555	CLAMP COLLAR "B"
24	2316285	MOTOR ASSEMBLY 36V 4" VARS (52")	82	2267800	GEAR-INDICATOR	152	2072621	PIN-KNURLED
	2316289	MOTOR ASSEMBLY 36V VARS TXT (62")	83	2372100	SCREW-8-18 X 5/8 SS	153	2281505	KNOB-CLAMP COLLAR
	2326286	MOTOR ASSEMBLY 36V 4" VARS 52" SONAR 2	84	2355410	SHRINK TUBE-3/8 OD X 2- [3.EA]	155	2071718	WASHER #10 NYLON RETAINING
	2326287	MOTOR ASSEMBLY 36V 4" VARS 62" SONAR 2	85	2232360	PULLEY-CABLE DRUM	157	2073102	NUT - HEX 1/4 - 28 SS
25	2032007	TUBE COMP W/4 HOLE 62"	86	2261730	WASHER-NYLON	158	2071560	SPLIT COLLAR
	2032006	TUBE COMP W/4 HOLE 52"	87	2996247	PINION/RACE ASSEMBLY	159	2211410	EXTENSION CABLE- US2
■	1378132	PROPELLER KIT	88	2223468	SCREW-8-32 X 7/16 ZN PL [4.EA]	160	2263804	STRAP - VELCRO 30.5"
26	2331160	PROPELLER W.WEDGE 2	89	2262607	PIN- CLEVIS ZP	161	2263615	TIE RAIL LONG [2 EA.]
27	2091701	WASHER-PROP LARGE	90	2260800	SPRING CLIP SS	162	2262645	LATCH PIN HOLDER [2 EA.]
28	2093101	NUT-PROP NYLOCK SS	91	2150400	PULL-GRIP	163	2263456	SCREW #8 - 3/4" BTFH SS [4 EA.]
29	2262658	PIN-DRIVE SS	92	2151700	WASHER-EYE SHAFT .562 OD	164	2262661	LATCH PIN, GROOVED FRONT SS
■	2991742	MOUNT,BOW ASSEMBLY, FW 62"	93	2994496	FOOT PEDAL/PLUG ASSEMBLY	165	2262663	LATCH PIN, GROOVED REAR SS
	2991741	MOUNT,BOW ASSEMBLY, FW 52"	94	2993705	PUSH BUTTON / MAGNET ASSEMBLY	166	2261990	BRACKET, CYLINDER FRONT
36	2264255	ARM UPPER-FW LONG	95	2302732	SPRING-LOWER PEDAL SS	167	2262665	PIN, FRONT SHOCK MOUNT
37	2293501	BUSHING, STAINLESS STEEL [4.EA]	97	2260810	CLIP, REED SWITCH	168	2332104	SCREW 1/4-20 X 5/8" PH SS [2 EA.]
38	2263500	BOLT, SHOULDER MAXXUM [2.EA]	99	2280115	KNOB-SPEED CONTROL VAR	169	2073100	1/4-20" NUT SS [2 EA.]
■	2774335	LOWER ARM ASSEMBLY, LONG, FW, 101#	100	2263000	E-RING TRU-ARC#5133-43	170	2263006	E-CLIP 5/16" SHAFT SS [2 EA.]
39	2264335	ARM-LOWER ASSEMBLY,LG,FW,EXT	101	2266413	PLATE -TENSION SCREW FTPED.	171	2261995	BRACKET REAR [2 EA.]
40	2263913	MOTOR REST LONG MAXXUM	102	2260511	PIN-PIVOT A/T PT PDL	172	2223454	SCREW #10-32 X 1/2" PH SS [4 EA.]
41	2265508	DECAL-MAXXUM,MOTOR REST [2.EA]	103	2774550	FT PEDAL BASE/PIN ASSEMBLY	173	2261545	YOKE-GAS ASSIST
42	2773986	BOWPLATE- FW LG MACH/INSERT	104	2262301	PULLEY- FOOT PEDAL	174	2262722	SPRING EXTENSION
43	2251601	ROPE 40" MAXXUM MOUNT	105	2223430	SCREW #8X3/4 PPH TYPE 25 SS [4.EA]	175	2262635	PIN ROLLER SS [2 EA.]
44	2261708	WASHER-3/8X1/2X.010 SS [2.EA]	106	2266400	COVER-PULLEY STAMPING	176	2262667	PIN-KNURLED SS
45	2267318	BEARING NYLINER- [2.EA]	107	2301310	SCREW-8-18 X 1/2 SS [2.EA]	177	2262669	PIN-YOKE PIVOT SS
46	2152610	SPRING-PIN LOCKBAR [2.EA]	108	2264054	CONTROL BOARD ASSEMBLY 24V MAX	178	2262320	ROLLER YOKE [2 EA.]
47	2233600	LOCK BAR- BOW MOUNT	109	2365107	INSULATING PAD 2.3 X 3.2	179	2998431	CYLINDER/SHOCK BOOT ASSEMBLY
48	2233602	LOCK BAR- REAR ZINC	111	2263455	SCREW, 10-32 X 1/2 [2.EA]	180	2262670	LATCH PIN STOP LEVER
49	2152700	SPRING-LOCKBAR CAD.PLT	112	2261220	WIRE HARNESS AT & MAX 82.5	181	2262723	SPRING, MAXXUM PRO
50	2262703	SPRING STOP	113	2267505	CABLE ASSEMBLY-RIGHT 5'	182	2301700	SPACER-RELEASE LEVER BRASS
51	2153604	EYE SHAFT-2LOCKBAR LG-PLTD	114	2267515	CABLE ASSEMBLY-LEFT 5'	183	2332104	SCREW 1/4-20 X 5/8" SS
52	2260506	HINGE-PIN HEADLESS ZINC	115	2265430	CABLE JACKET 5'	200	2075120	URETHANE PAD
■	2772088	TUBE W/BEARING RACE ASSEMBLY 28.5"	116	2265110	BOOT-CONTROL BOX			
	2772086	TUBE W/BEARING RACE ASSEMBLY 24"	117	2265115	BOOT-FOOT PEDAL BASE			
54	2272088	TUBE OUTER 28.5" 62"	118	2372100	SCREW-8-18 X 5/8 THD SS [2.EA]			
	2272086	TUBE OUTER 24" 48"-52"	119	2261714	WASHER-MAXXUM PT PDL [2.EA]			
55	2266260	BEARING RACE-(565T)	120	2261901	BRACKET-CONDUIT AT/MAX			
57	2267307	BUSHING, OUTER TUBE	121	2263210	BRACKET-CONDUIT ADJUSTMENT			
■	2991763	BOWGUARD ASSEMBLY MAX	122	2263104	NYLOCK KEEPER			

2889460 Seal & Oring Kit

Max 101 is 36-volt only!

OPTIONAL BROWN WIRE *
SEE BOAT WIRING DIAGRAM
FIL MARRON OPTIONNEL *
ÉQUIPÉS DE SONAR. VOYEZ LE SCHÉMA DE CÂBLAGE DU BATEAU.

