

MotorGuide REPAIR PARTS

Model: **POWER** *plus*
F60V

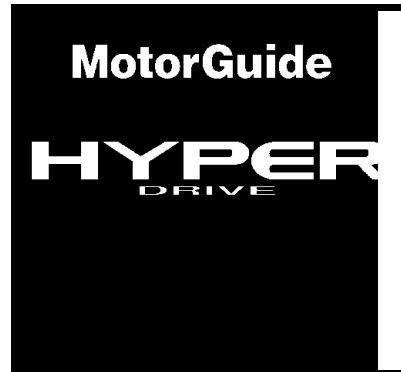

SPECIFICATIONS:

Year of Intro	1999
Thrust	60LBS
Volts	24VDC
Amp Draw	0 to 33amps
Mount	20 Bow
Speeds	Variable

QUICK REFERENCE PARTS GUIDE:

Momentary switch	AP151-01
Toggle Switch	FP153-03
DA Board	JF157-02
MOSFET	JF096-08
Motor Seal Kit	6220

PARTS ORDERING & TECH ASSISTANCE

MotorGuide Consumer Relations
 Phone 918-831-6989
 Fax 800-982-8093

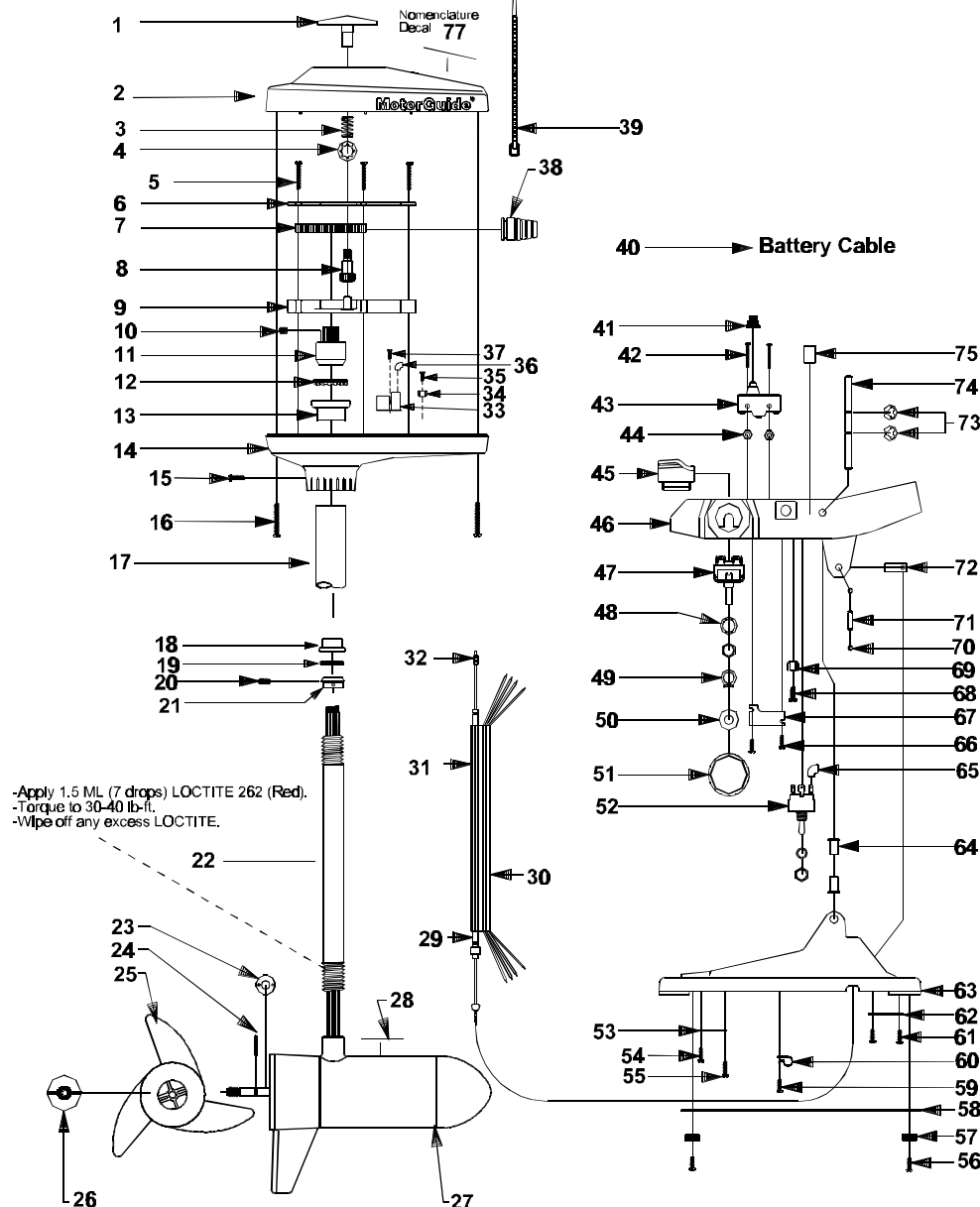

KEY#	PART#	DESCRIPTION	KEY#	PART#	DESCRIPTION	KEY#	PART#	DESCRIPTION
1	JF078-04	INDICATOR	26	AR099-01	PROP NUT	52	FP153-03	TOGGLE SWITCH 3 POSITION
2	JF053-19	TH COVER GENERIC	27	UF397-05	LOWER UNIT	53	KP123-01	CABLE PLATE
3	AF014-01	COMPRESSION SPRING	28	ET060-05	LOWER UNIT DECAL	54	EK135-01	3^ SELF TAP SCREW
4	AF046-01	TINNERMAN CLIP	29	9377	63" CONTROL CABLE	55	AF135-01	6 X 1/2" SCREW
5	AF133-01	#6 RACK GUIDE SCREW	30	MM9006-02	OUTER JACKET	56	AF135-01	6 X 1/2" SCREW
6	AF127-01	RACK GUIDE COVER	31	LP327-11	STUFFED CABLE ASY	57	KP023-01	FOOT PEDAL PAD
7	AP125-01	RACK	32	AP141-01	CONTROL CABLE STUD	58	LP3123-01	WEIGHT PLATE ASY
8	AF069-01	INDICATOR GEAR	33	JF157-02	24V DURA AMP BOARD	59	AF135-01	6 X 1/2" SCREW
9	AF126-01	RACK GUIDE	34	FT160-03	TERMINAL 4 PRONG	60	KP036-01	BATTERY CABLE CLAMP
10	AF142-01	1/4 NUT SET SCREW	35	AF135-01	6 X 1/2" SCREW	61	IR133-01	SCREW
11	AF398-02	NUT SUB ASY	36	AT080-01	INSULATING SLEEVE	62	KP036-02	BATTERY CABLE CLAMP
12	AF005-01	BALL BEARING	37	AF141-01	SELF TAPPING SCREW	63	LP003-01	FOOT PEDAL BASE
13	AF007-01	BEARING CUP	38	AP071-01	GROMMET	64	KP021-01	SHAFT BUSHING
14	JF004-03	TH BASE	39	AF030-01	CABLE TIE	65	AT080-01	INSULATING SLEEVE
15	AP133-01	6 X 5/8 SCREW	40	KP328-06	BATTERY CABLE ASY	66	AF135-01	36 X 1/2 SCREW
16	AR133-01	8 X 1 3/8 SCREW	41	KP157-01	MICRO SWITCH BOOT	67	LP123-03	RETAINER PLATE
17	AF165-06	OUTER TUBE	42	LP135-01	#6-32 X 1 1/2 SCREW	68	GR133-01	#10 X 1/2 SCREW
18	FM007-01	BEARING CUP	43	AP151-01	MICRO SWITCH	69	FT160-03	TERMINAL 4 PRONG
19	FM005-01	BALL BEARING	44	SP098-02	#6-32 NUT SS	70	FP046-01	E RING
20	AF143-01	CONE SET SCREW	45	LP026-01	MICRO BUTTON	71	AP105-01	CABLE PIVOT PIN
21	AF006-01	BEARING CONE	46	LP101-02	FOOT PEDAL MARINE	72	LP091-01	CABLE PIVOT
22	AF049-09	42" COLUMN	47	AP168-02	VARIABLE POTENTIOMETER	73	BK046-02	E RING
	AF049-08	36" COLUMN	48	KP171-01	LOCK WASHER 3/8	74	LP102-01	FOOT PEDAL ROCKER PIN
23	RK171-01	NYLON WASHER	49	LP046-01	GRIP RING	75	LP057-03	TOGGLE SWITCH DECAL
24	BR102-01	PROP PIN	50	AK171-02	NYLON WASHER	76		
25	AF124-07	2 BLADE PROP	51	LP082-06	VARIABLE SPEED KNOB	77	JF056-16	NOMECLATURE DECAL

LOWER UNIT BREAKDOWN

Model:
F60V

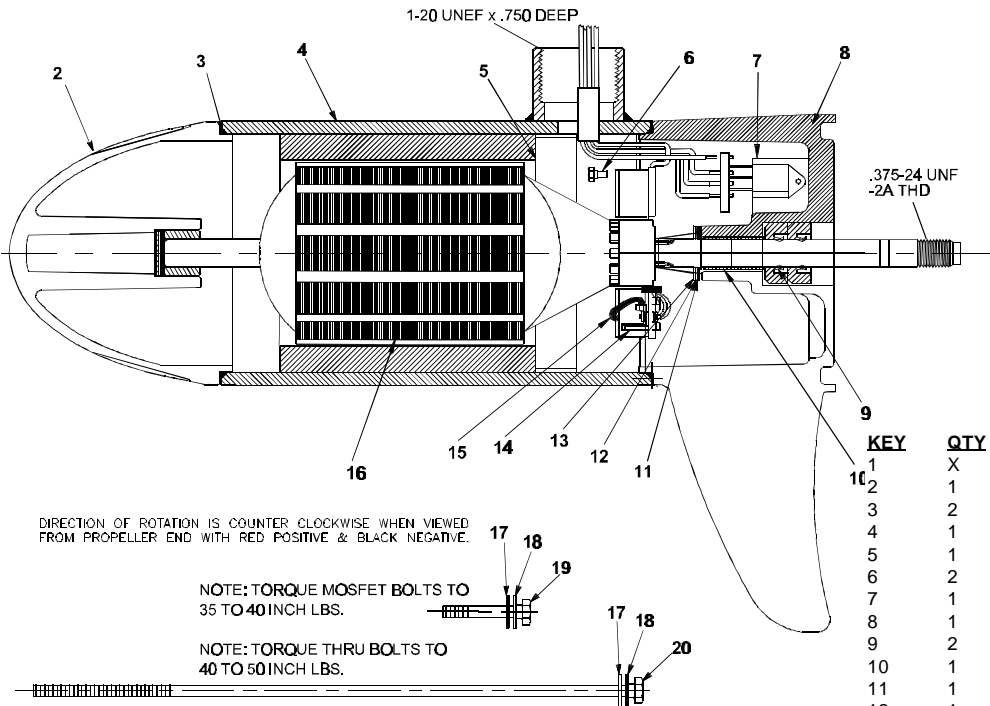

DIRECTION OF ROTATION IS COUNTER CLOCKWISE WHEN VIEWED FROM PROPELLER END WITH RED POSITIVE & BLACK NEGATIVE.

NOTE: TORQUE MOSFET BOLTS TO 35 TO 40 INCH LBS.

NOTE: TORQUE THRU BOLTS TO 40 TO 50 INCH LBS.

KEY	QTY	DESCRIPTION	PART NO.
1	X	MOTOR	UF397-05
2	1	NOSE CAP	XF3212-01
3	2	O RING SEAL	MR217-01
4	1	HOUSING ASY	UF3210-01
5	1	RETAINER	JF233-01
6	2	BRUSH CARD SCREW	MR228-01
7	1	DURA AMP MODULE	JF096-08
8	1	COMM CAP	UF3205-05
9	2	SHAFT SEAL	MR223-01
10	1	BEARING	MR206-01
11	1	NYLATRON WASHER	MR226-01
12	1	WASHER	MR227-01
13	1	E RING	MR219-02
14	2	BRUSH SPRINGS	MR214-02
15	1	BRUSH ASY LESS SPRING	UF3201-05
16	1	ARMATURE 3.5"	UF3207-01
17	4	STATIC SEAL	MR222-01
18	4	THRU BOLT WASHER	MR216-01
19	2	DURA AMP SCREW	MR229-04
20	2	THRU BOLT	MR218-02

WIRING

SUBJECT TO DAMAGE BY STATIC ELECTRICITY ASSEMBLE AT STATIC FREE WORK STATION.

 SUBJECT TO DAMAGE BY STATIC ELECTRICITY ASSEMBLE AT STATIC FREE WORK STATION!

