

Model: ENERGY
ET54V

SPECIFICATIONS:

Year of Intro 2000
Thrust 54 LBS
Volts 12VDC
Amp Draw 0 to 48 amps
Mount 09 Transom
Speeds Variable

TO ORDER PARTS:

MotorGuide Consumer Relations
Phone 918-831-6989
Fax 800-982-8093

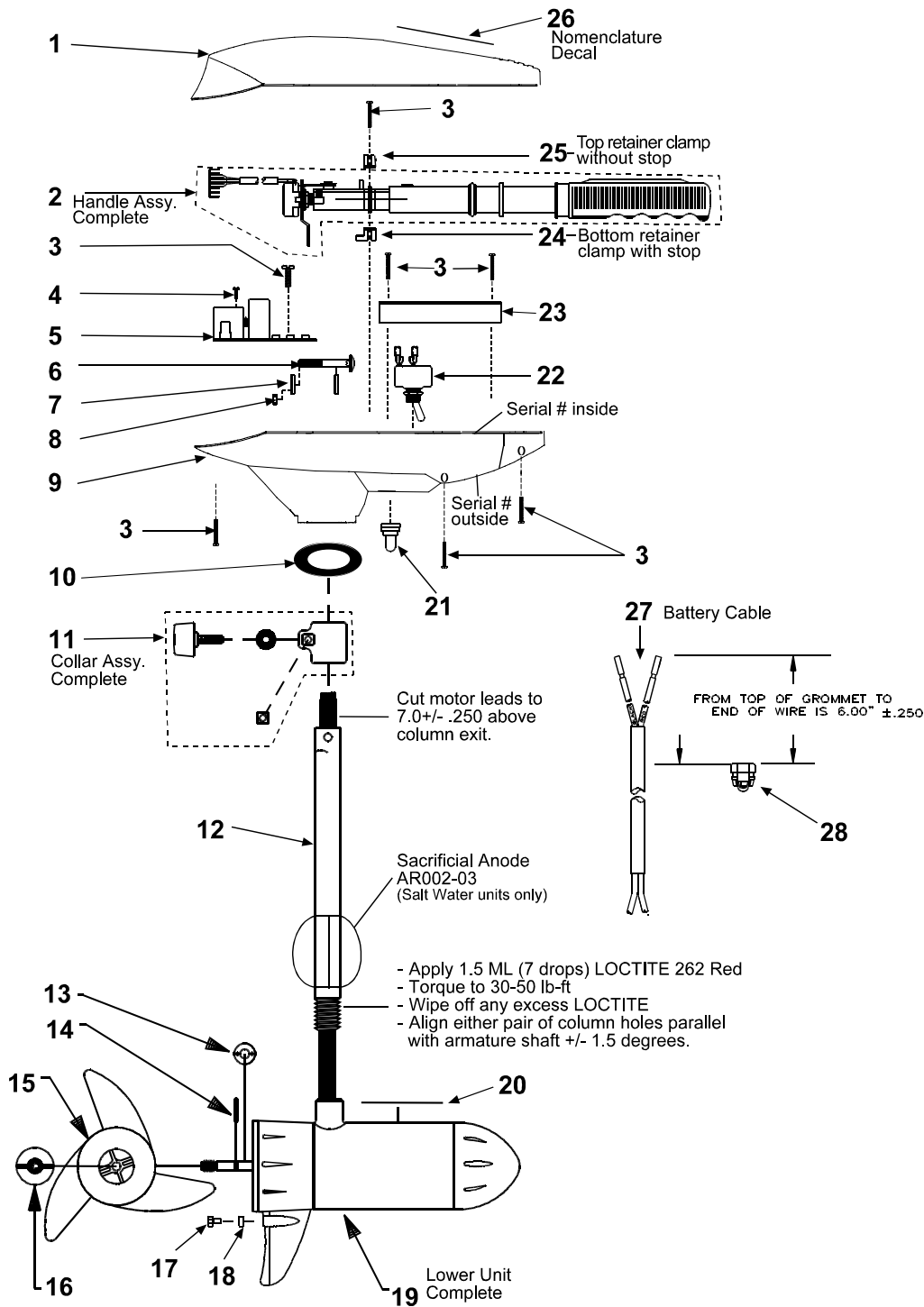

KEY	DESCRIPTION	PART #	KEY	DESCRIPTION	PART #	KEY	DESCRIPTION	PART #
1	TOP HOUSING COVER BLACK	ET053-17	12	COLUMN 36"	TT049-05	20	LOWER UNIT COMPLETE	ET060-08
2	HANDLE ASY	ET372-06	13	COLUMN 42"	TT049-06	21	SWITCH BOOT	FP177-01
3	#8 X 5/8 SCREW	AT141-01	14	COLUMN 50"	FR049-13	22	TOGGLE SWITCH	FP153-07
4	#4 SELF TAPPING SCREW	XT141-02	15	MONOFILAMENT WASHER	AR175-01	23	CABLE PLATE	AT155-06
5	BOARD FOR/REV	AT157-01	16	PROP DRIVE PIN	BR102-01	24	BOTTOM RETAINER CLAMP	AR036-02
6	BOLT	TT134-02	17	PROP/3 BLADE	AF124-12	25	UPPER RETAINER CLAMP	AR036-04
7	CURVED WASHER	TT171-08	18	PROP/2 BLADE	AF124-07	26	NOMENCLATURE DECAL	ET056-10
8	NYLON LOCK NUT	XT098-02	19	MOTOR	AR099-01	27	BATTERY CABLE	XT328-06
9	T/H BASE BLACK	AT004-11			DK133-01	28	GROMMET	GR019-01
10	COLUMN SEAL	AT079-01			AR002-02			
11	DEPTH ADJUSTMENT COLLAR	AR158-01			CF397-16			

LOWER UNIT BREAKDOWN

Model: **ENERGY**
ET54V

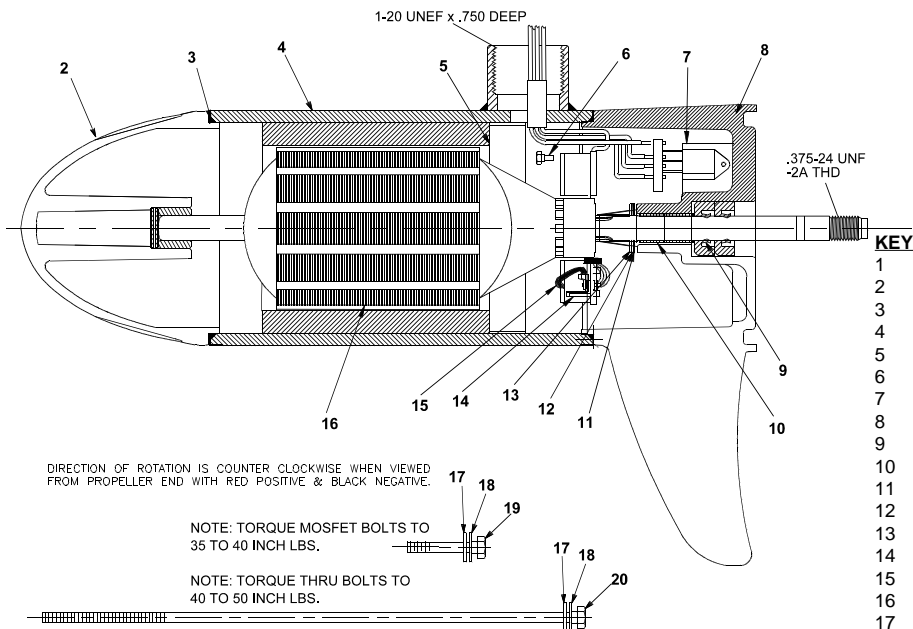

KEY	QTY	DESCRIPTION	PART NO.
1	X	MOTOR	CF397-16
2	1	NOSE CAP	XF3212-01
3	2	O RING SEAL	MR217-01
4	1	HOUSING ASY	UF3210-05
5	1	RETAINER	JF233-01
6	2	BRUSH CARD SCREW	MR228-01
7	1	DURA AMP MODULE	JF096-08
8	1	COMM CAP	XF3205-01
9	2	SHAFT SEAL	MR223-01
10	1	BEARING	MR206-01
11	1	NYLATRON WASHER	MR226-01
12	1	WASHER	MR227-01
13	1	E RING	MR219-02
14	2	BRUSH SPRINGS	MR214-02
15	1	BRUSH ASY LESS SPRING	UF3201-05
16	1	ARMATURE	CF3207-01
17	4	STATIC SEAL	MR222-01
18	4	THRU BOLT WASHER	MR216-01
19	2	DURA AMP SCREW	MR229-04
20	2	THRU BOLT	MR218-02

WIRING

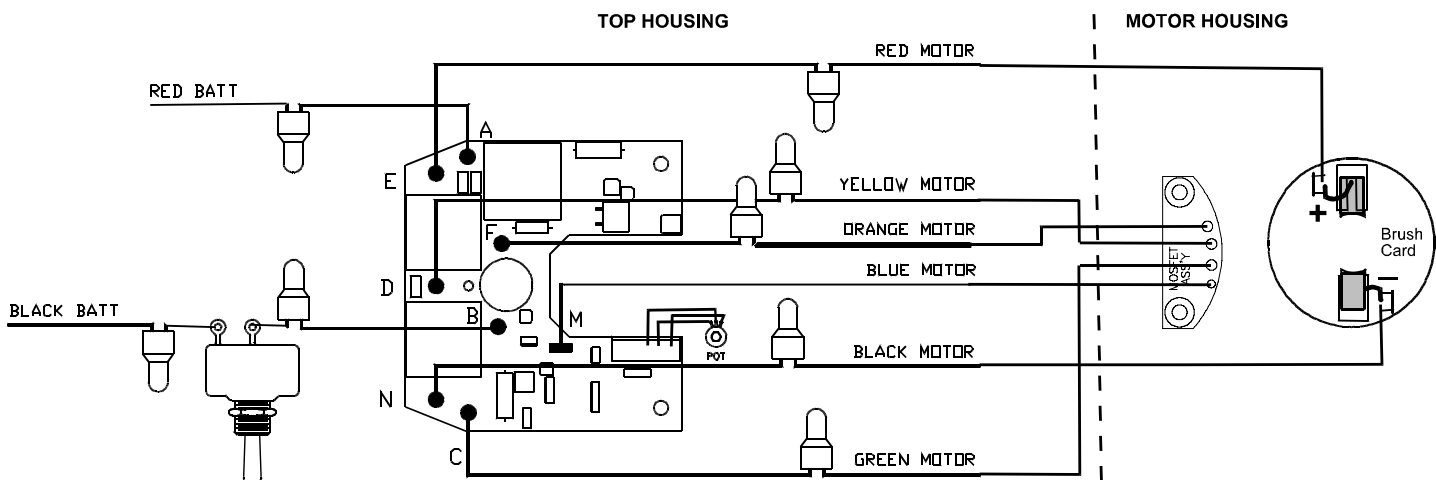
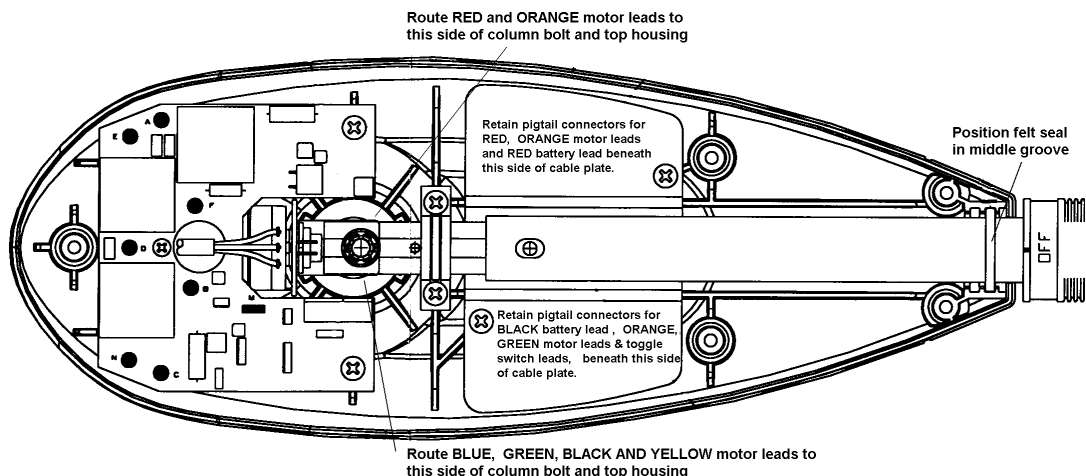

 SUBJECT TO DAMAGE BY STATIC ELECTRICITY
ASSEMBLE AT STATIC FREE WORK STATION!