

Model: ENERGY
ET46V

SPECIFICATIONS:

Year of Intro 2000
 Thrust 46 LBS
 Volts 12VDC
 Amp Draw 0 to 48 amps
 Mount 09 Transom
 Speeds Variable

TO ORDER PARTS:

MotorGuide Consumer Relations
 Phone 918-831-6989
 Fax 800-982-8093

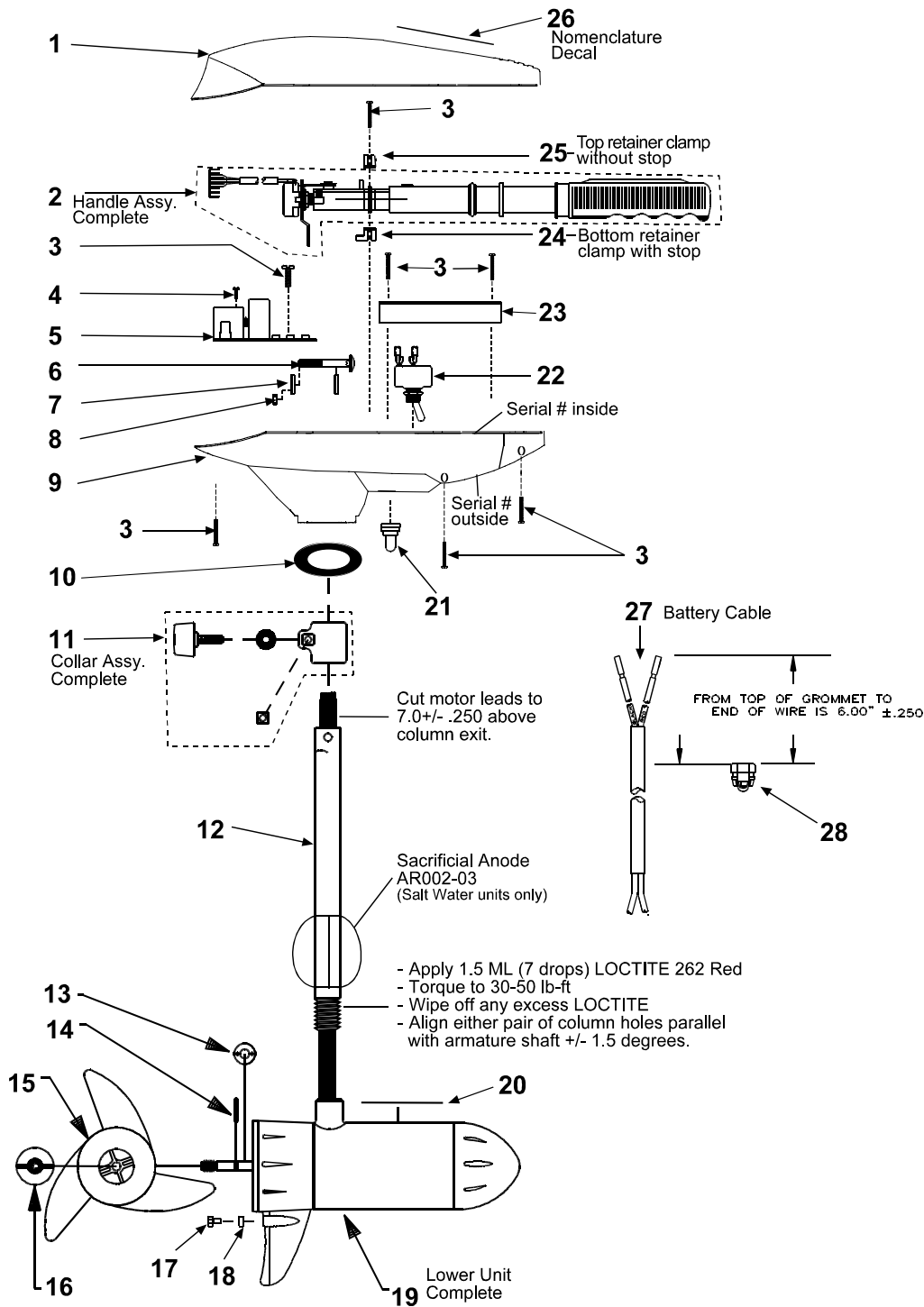

KEY	DESCRIPTION	PART #	KEY	DESCRIPTION	PART #	KEY	DESCRIPTION	PART #
1	TOP HOUSING COVER BLACK	ET053-17	12	COLUMN 36"	TT049-05	20	LOWER UNIT DECAL	ET060-08
2	HANDLE ASY	ET372-06	13	COLUMN 42"	TT049-06	21	SWITCH BOOT	FP177-01
3	#8 X 5/8 SCREW	AT141-01	14	COLUMN 50"	FR049-13	22	TOGGLE SWITCH	FP153-07
4	#4 SELF TAPPING SCREW	XT141-02	15	MONOFILAMENT WASHER	AR175-01	23	CABLE PLATE	AT155-06
5	CIRCUIT BOARD FOR/REV	AT157-01	16	PROP DRIVE PIN	BR102-01	24	BOTTOM RETAINER CLAMP	AR036-02
6	BOLT	TT134-02	17	PROP/3 BLADE	AF124-12	25	UPPER RETAINER CLAMP	AR036-04
7	CURVED WASHER	TT171-08	18	PROP/2 BLADE	AF124-07	26	NOMENCLATURE DECAL	TT056-11
8	NYLON LOCK NUT	XT098-02	19	PROP NUT	AR099-01	27	BATTERY CABLE	XT328-06
9	T/H BASE BLACK	AT004-11			DK133-01	28	GROMMET	GR019-01
10	COLUMN SEAL	AT079-01			AR002-02			
11	DEPTH ADJUSTMENT COLLAR	AR158-01			KF397-08			

LOWER UNIT BREAKDOWN

Model: **ENERGY**
ET46V

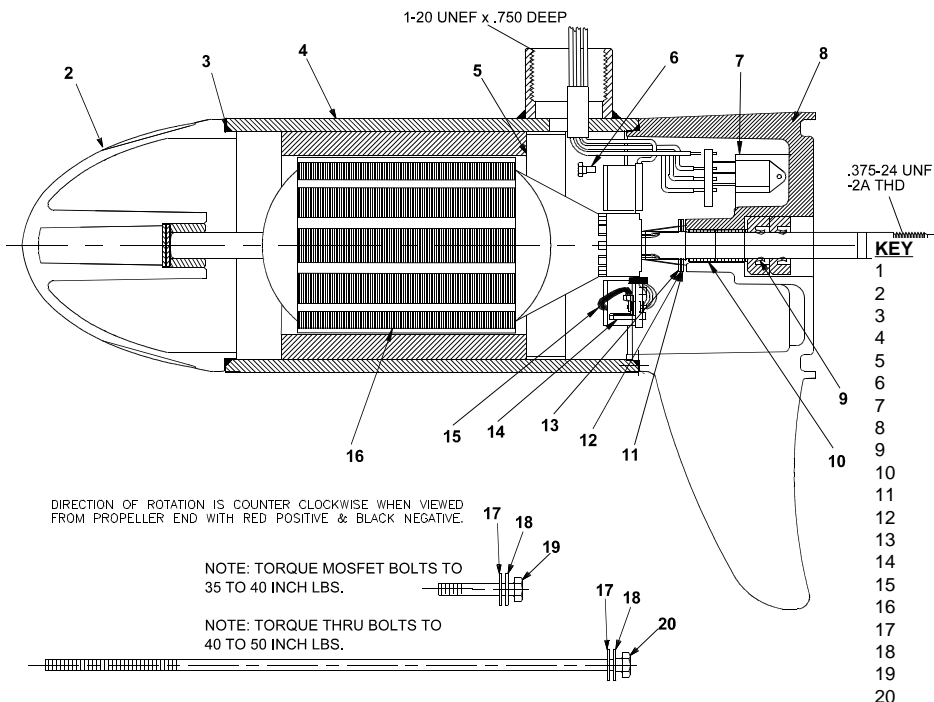

DIRECTION OF ROTATION IS COUNTER CLOCKWISE WHEN VIEWED FROM PROPELLER END WITH RED POSITIVE & BLACK NEGATIVE.

NOTE: TORQUE MOSFET BOLTS TO 35 TO 40 INCH LBS.

NOTE: TORQUE THRU BOLTS TO 40 TO 50 INCH LBS.

WIRING

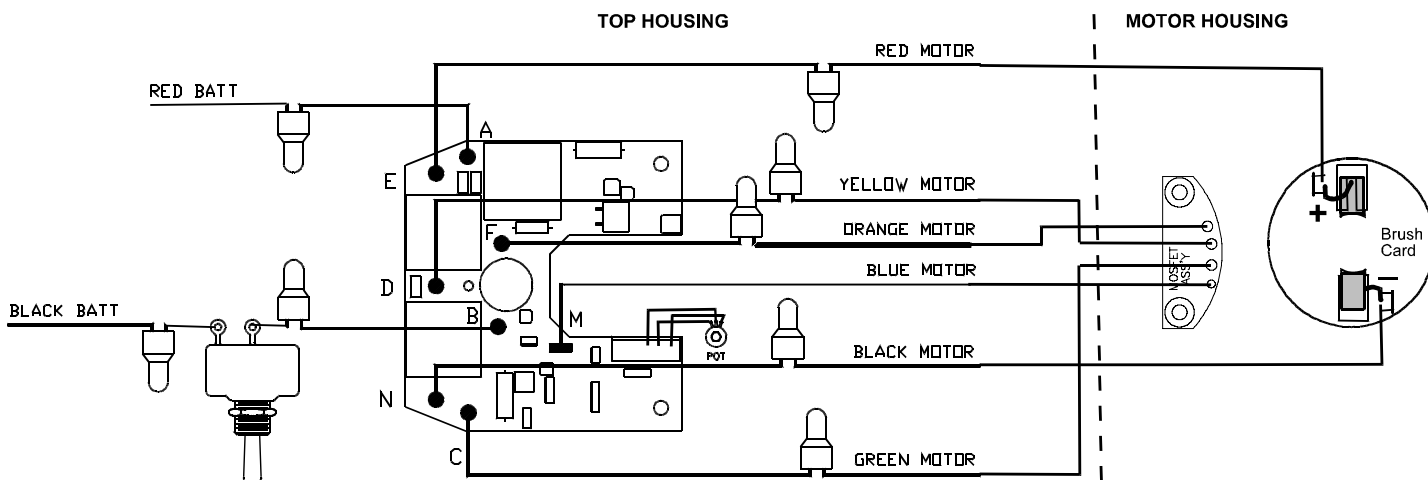
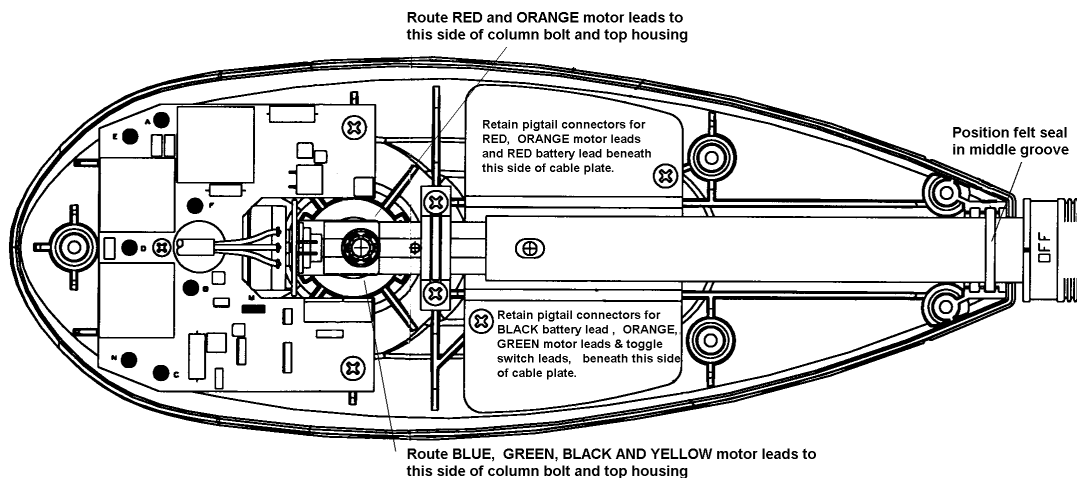

 SUBJECT TO DAMAGE BY STATIC ELECTRICITY
ASSEMBLE AT STATIC FREE WORK STATION!