

# MotorGuide® REPAIR PARTS

**Model:** ENERGY  
**ET30**

**SPECIFICATIONS:**

Year of Intro	2000
Thrust	30 LBS
Volts	12VDC
Amp Draw	0 to 48 amps
Mount	03 Transom
Speeds	5\2

**PARTS ORDERING & TECH ASSISTANCE**

MotorGuide Consumer Relations  
Phone 918-831-6989  
Fax 800-982-8093

*Returned Goods must be accompanied with a Returned Goods Authorization. Contact MotorGuide Consumer Relations to obtain RGA.*

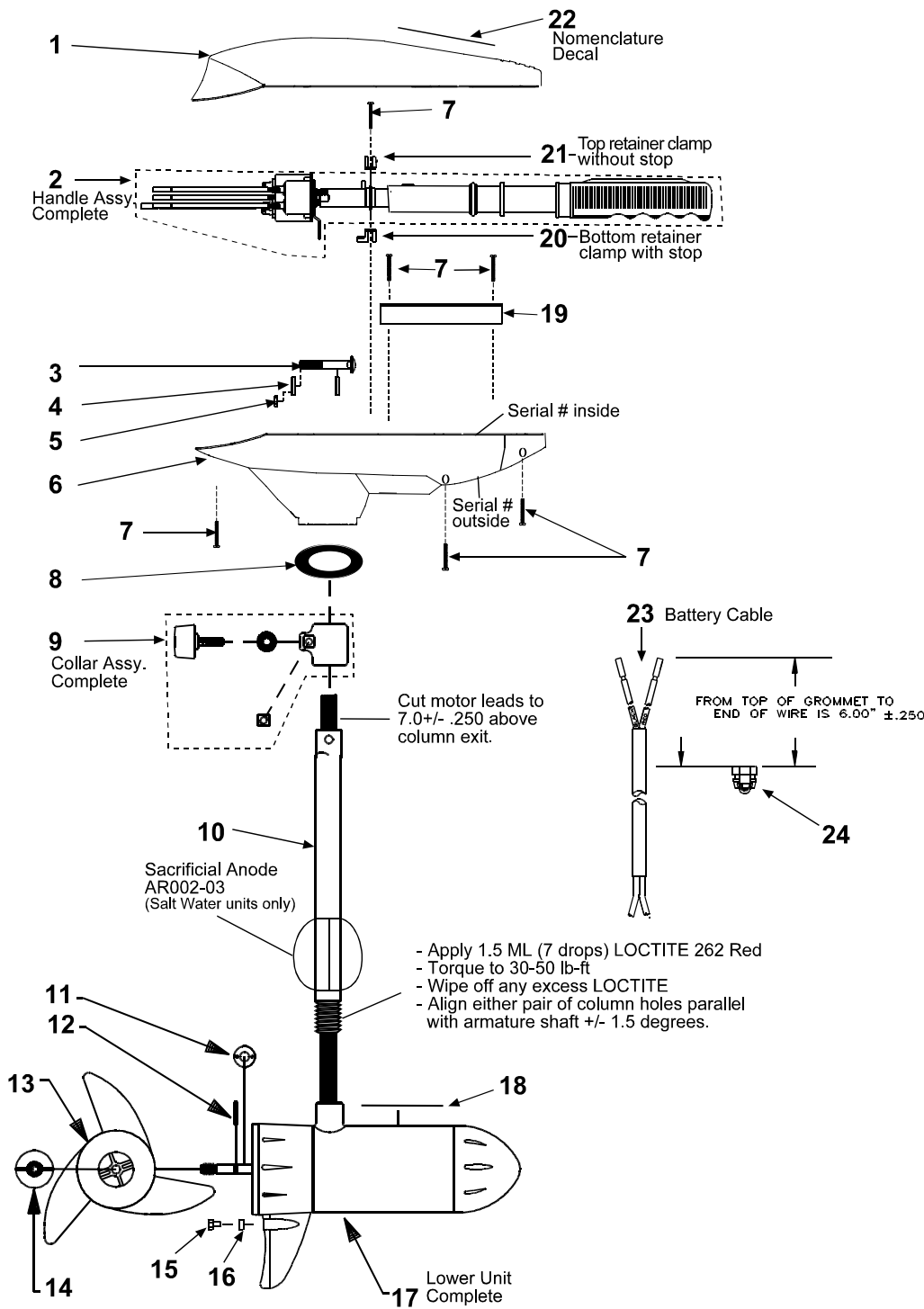

KEY	DESCRIPTION	PART #	KEY	DESCRIPTION	PART #	KEY	DESCRIPTION	PART #
1	TOP HOUSING COVER BLACK	ET053-17	10	COLUMN 36"	TT049-05	16	ANODE (Saltwater models only)	AR002-02
2	HANDLE ASY	BT372-09		COLUMN 42"	TT049-06	17	MOTOR	HM397-05
3	BOLT	TT134-02		COLUMN 50"	FR049-13	18	LOWER UNIT DECAL	ET060-08
4	CURVED WASHER	TT171-08	11	MONOFILAMENT WASHER	AR175-01	19	CABLE PLATE	AT155-06
5	NYLON LOCK NUT	XT098-02	12	PROP DRIVE PIN	BR102-01	20	BOTTOM RETAINER CLAMP	AR036-05
6	T/H BASE BLACK	ET004-16	13	PROP/3 BLADE	AF124-12	21	UPPER RETAINER CLAMP	AR036-04
7	#8 X 5/8 SCREW	AT141-01	22	PROP/2 BLADE	AF124-07	22	NOMENCLATURE DECAL	KT056-14
8	COLUMN SEAL	AT079-01	14	PROP NUT	AR099-01	23	BATTERY CABLE	XT328-06
9	DEPTH ADJUSTMENT COLLAR	AR158-01	15	ANODE BOLT (Saltwater models only)	DK133-01	24	GROMMET	GR019-01

# LOWER UNIT BREAKDOWN

**Model:**  
**ET30**

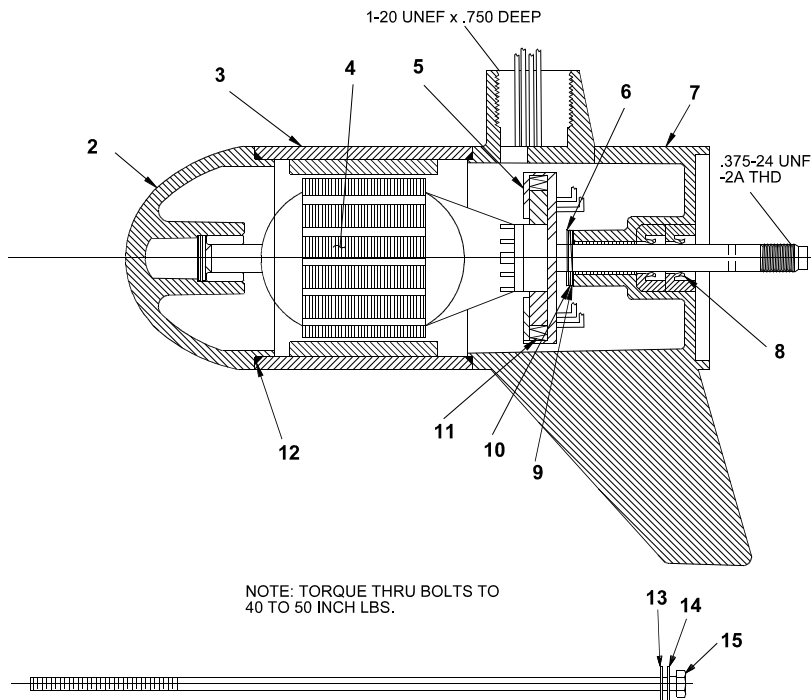

KEY	QTY	DESCRIPTION	PART NO.
1	X	MOTOR	HM397-05
2	1	NOSE CAP	FF3212-03
3	1	HOUSING ASY	FF3210-07
4	1	ARMATURE 3"	HM3207-01
5	1	BRUSH ASY LESS SPRING	FF3205-04
6	1	E RING	MR219-02
7	1	COMM CAP	RT3205-02
8	2	SHAFT SEAL	MR223-01
9	1	NYLATRON WASHER	MR226-01
10	1	WASHER	MR227-01
11	2	BRUSH SPRINGS	MR214-02
12	2	O RING SEAL	HF217-01
13	4	STATIC SEAL	MR222-01
14	4	THRU BOLT WASHER	MR216-02
15	2	THRU BOLT	MR218-05
16	1	BRUSH CARD	FF3201-02

## WIRING

