

SPINCASTING REEL

Goldcast 310RL

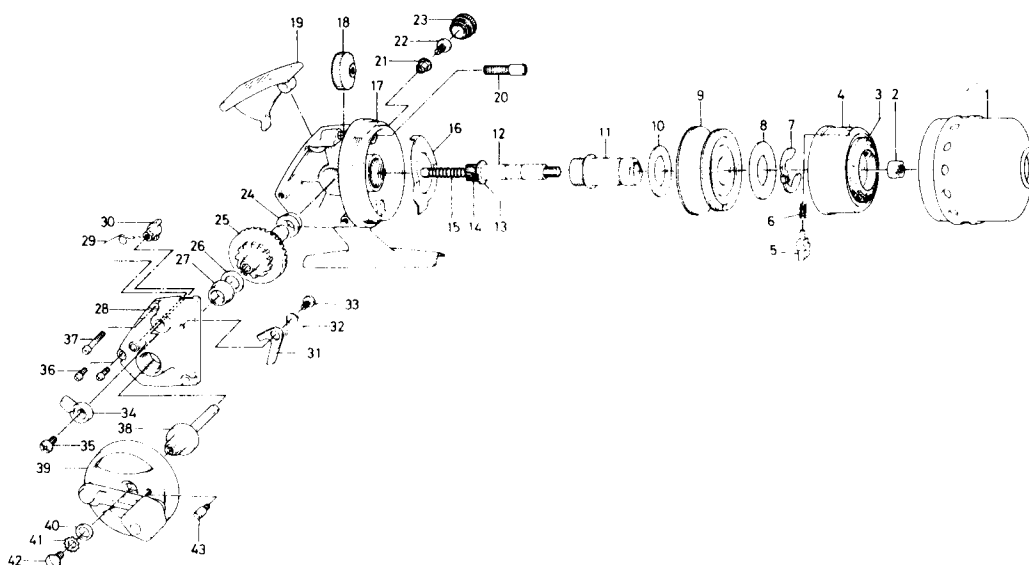

KEY NO. 3 ~ 6
6-736-6502

ROTOR ASSEMBLY

KEY NO. 12 ~ 15
6-711-1631

MAIN SHAFT ASSEMBLY

Key No.	Parts No.	Parts Name	Key No.	Parts No.	Parts Name
1	755-1303	Front cover	23	B03-4802	Handle screw cap
2	342-3701	Rotor nut	24	637-4801	Drive gear shaft holder
3	330-4311	Line stopper	25	413-5201	Drive gear
4	736-6402	Rotor	26	370-5100	Drive gear washer
5	180-3512	Pick up pin	27	637-4801	Drive gear shaft holder
6	142-4501	Pick up pin spring	28	062-9905	Body cover
7	320-9101	Spool retainer	29	B09-1401	Anti-reverse cam spring
8	370-0412	Spool washer	30	461-4501	Anti-reverse cam
9	732-1732	Spool	31	111-7011	Anti-reverse claw
10	370-0412	Spool washer	32	144-5111	Anti-reverse claw spring
11	381-7511	Shaft metal	33	351-7701	Anti-reverse claw screw
12	393-3821	Main shaft	34	541-3132	Anti-reverse lever
13	633-8811	Ball bearing	35	351-4701	Anti-reverse lever screw
14	402-6401	Pinion	36	351-1101	Body cover screw (short)
15	142-7711	Main shaft spring	37	353-4911	Body cover screw (long)
16	151-6501	Drag adjusting plate	38	071-0503	Drive gear shaft
17	700-8821	Body	39	746-6001	Handle
18	B12-3001	Drag adjusting dial	40	375-2501	Handle washer A
19	781-6308	Push button	41	160-8001	Handle washer B
20	363-5911	Drag adjusting screw	42	352-1101	Handle screw B
21	501-8501	Handle screw holder	43	363-6201	Handle arm stopper screw
22	363-8511	Handle screw A			