

ALCEDO SPINNING REELS

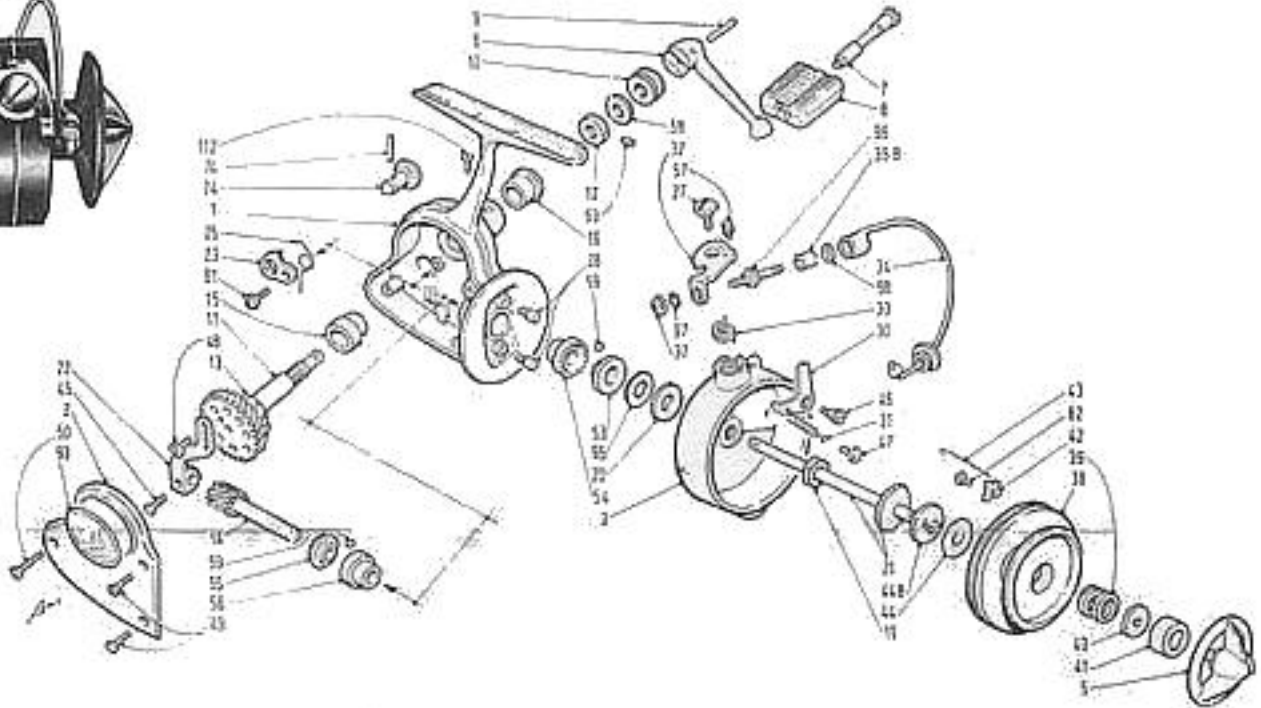

ALCEDO 2C/S



How to Order Parts for Alcedo Reels
Please refer to the parts numbers listed on this sheet. If in doubt, send your old part to us for identification and replacement. All orders for parts should be accompanied by payment in full including an estimated amount to cover shipping and insurance and addressed to:

CONTINENTAL ARMS CORP.
697 FIFTH AVE., NEW YORK, N.Y. 10022

ALCEDO 2C/S PARTS LIST

No.	Part Name	Price	No.	Part Name	Price
1.	Housing	12.50	37.	Retaining nut for ball pick-up	.50
2.	Housing cover	2.50	38.	Line spool	8.50
3.	Spinner cup	6.00	39.	Brake spring	1.00
5.	Brake nut	2.00	40.	Brake spring washer	.50
6.	Winding arm	2.50	41.	Retaining cup for brake spring	.50
7.	Screw for handle grip	.60	42.	Spool click pawl	.50
8.	Handle grip	2.00	43.	Spool click spring	.30
9.	Hinge pin for winding arm	.30	44.	Brake washer (metal)	.20
10.	Lock nut for winding arm	1.50	44B.	Brake washer (felt)	.20
11.	Driver gear	8.50	45.	Retaining screw for connecting rod	.30
12.	Adjustable thrust collar for driver gear	1.50	46.	Release lever or pawl (part 42) retaining screw	.30
13.	Anti reverse ratchet	1.50	47.	Mounting screw for bail release lever spring	.30
14.	Driven sleeve gear	5.00	48.	Crank pin	.50
15.	Inner bushing for driven gear	2.00	49.	Cover screw, short (2)	.30
16.	Outer bushing for driver gear	2.00	50.	Cover screw, long	.30
19.	Lock nut for spinner cup	.50	53.	Upper ball race for upper thrust bearing	2.50
20.	Spacing collar	.30	54.	Lower ball race for upper thrust bearing	2.50
21.	Reciprocating shaft for spool	4.00	55.	Lower ball race for lower thrust bearing	2.50
22.	Connecting rod	2.50	56.	Upper ball race for lower thrust bearing	2.50
23.	Anti reverse pawl	1.00	57.	Rubber stop cushion for bail cam	.75
24.	Anti reverse button	2.00	58.	Inner lock out for winding arm	1.00
25.	Spring for anti reverse pawl	.60	59.	Bearing balls	ea. .20
27.	Retaining screw for bail cam	1.00	60.	Lock nut for thrust adjusting washer	.75
28.	Retaining screw for ball release roller	.50	61.	Retaining screw for anti reverse pawl	.50
29.	Ball release roller	.75	63.	Locking set screw for adjustable thrust collar	.30
30.	Ball release lever	2.00	74.	Pin for anti reverse button	.25
31.	Bail release lever spring	.50	93.	Alcedo name plate	1.50
32.	Ball cam	3.00	95.	Nylon spacing washer	.05
33.	Return spring for bail cam	1.00	96.	Line roller shaft	1.25
34.	Bail pick-up assembly (parts 34-35-96-97-98-37)	8.50	97.	Lock washer	.10
35.	Agate line guide roller	2.50	98.	Gasket	.05
			110.	Lower thrust adjusting washer	1.00
			112.	Cap screw for oil hole	.50

Instructions For Replacing Alcedo Bail Pick-up Spring

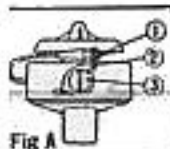

Fig A

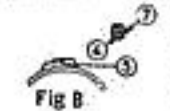

Fig B



Fig C

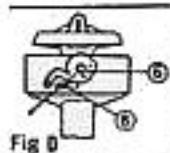

Fig D

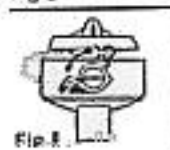

Fig E

☆ Unscrew and remove nut (1) which anchors the bail to the cam. Detach the bail itself to free it.

☆ Unscrew and remove large-headed screw (3) which anchors the cam. The cam will thus be disengaged and the broken spring can be removed.

☆ Assemble the new spring in place by holding it firmly between thumb and forefinger with straight end (4) pointing away from you. SQUEEZE SPRING AT AN ANGLE AS IN FIG. C which will cause straight end (4) to protrude out making it easier to locate hole (5) in Fig. B which is visible in the lower portion of spinner cup projection.

☆ Replace the cam (6) in the position shown in Fig. D by holding the cam stop (8) to the left with left thumb and placing cam in position with right hand inserting the hook of the spring (7) into one of the holes (6) preferably the middle one. These holes are provided so the tension of the spring can be regulated.

☆ Hold the cam (6) in this position with left thumb and forefinger centering the hole in the cam over the screw hole in the spinner cup projection. Holding it in this position, screw large screw (3) into place. During this operation some resistance may be encountered due to the fact that the two holes may not be exactly in line. In this event, do not force the screw, because the threads may be damaged. Instead, move the cam slightly until the screw threads turn easily.

☆ Turn the cam to the right until it regains its normal position (Fig. D). Replace the pick-up assembly into the cam.



FISHING TACKLE DIVISION
CONTINENTAL ARMS CORP.
697 FIFTH AVENUE, NEW YORK, N.Y. 10022

212-753-8331