

ARSENAL

AR15AL
AR20AL

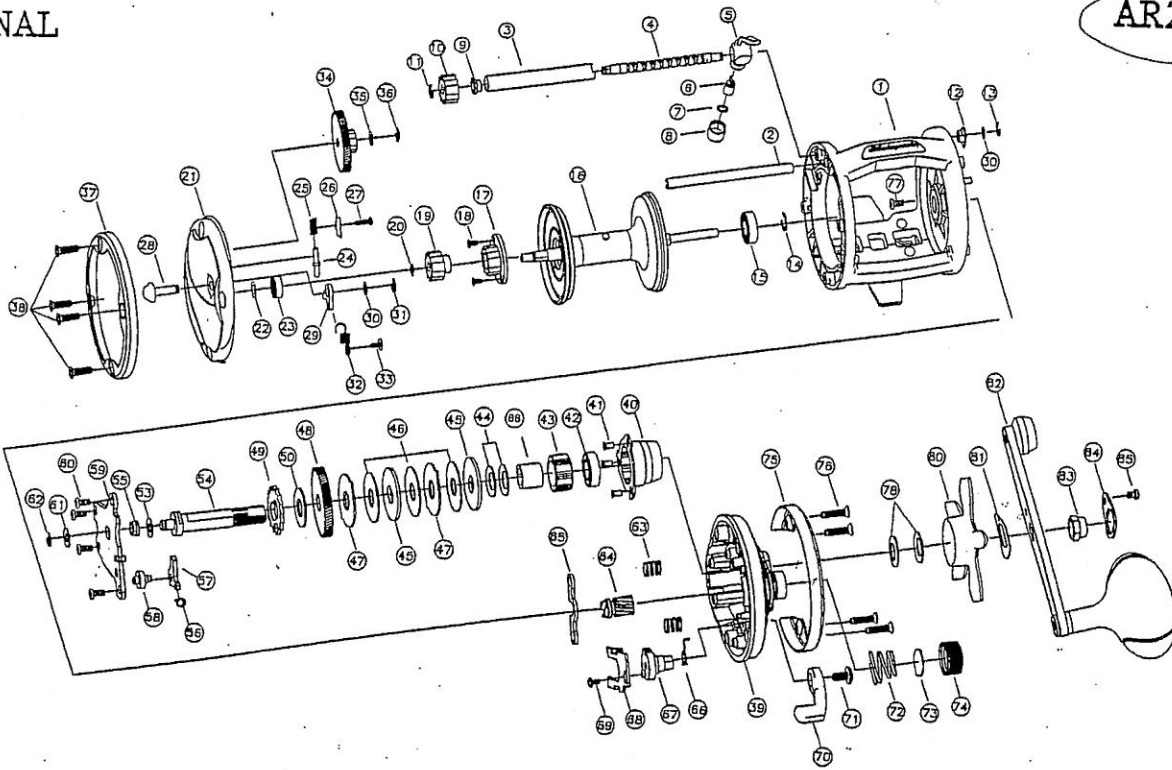

NO.	PART NAME
1	FRAME ASSM'
2	L-WIND SUPPORT SHAFT
3	WORM SHAFT GUIDE
4	WORM SHAFT
5	LEVEL WIND ASSM'
6	LEVEL WIND PAWL
7	SPACER
8	LEVEL WIND NUT
9	W-SHAFT BUSHING(LEFT)
10	IDLERS
11	"E" WASHER
12	W-SHAFT BUSHING(RIGHT)
13	"E" WASHER
14	C-RING-B
15	BALL BEARING
16	SPOOL ASSM'
17	CLICK WHEEL
18	CLICK WHEEL SCREW
19	LEVEL WIND DRIVE GEAR
20	C-RING
21	LEFT COVER
22	SPOOL SPACER
23	BUSHING
24	CLICK METAL
25	COIL SPRING
26	CLICK PLATE
27	CLICK METAL SCREW
28	CLICK SWITCH
29	CLICK CLAW

1146818
1145278
1145278
1146781

NO.	PART NAME
30	WASHER
31	"E" WASHER
32	CLICK SPRING
33	CLICK SPRING SCREW
34	IDLER GEAR
35	IDLER GEAR WASHER
36	"E" WASHER
37	PROTECTOR-L
38	PROTECTOR-L SCREW
39	RIGHT COVER
40	BEARING SLEEVE
41	BEARING SLEEVE SCREW
42	BALL BEARING
43	ONE WAY CLUTCH
44	SPRING WASHER
45	DRIVE WASHER(D)
46	DRIVE WASHER
47	EARE WASHER
48	DRIVE GEAR
49	AR RATCHET ASSM'
50	DRIVE SHAFT WASHER
53	WASHER
54	CRANK SHAFT
55	BUSHING
56	ANTI-REVERSE SPRING
57	ANTI-REVERSE PAWL
58	ANTI-REVERSE POST
59	SET PLATE

1146825
1145283
1146828
1145278
1145079
1146895
1146825

NO.	PART NAME
60	SET PLATE SCREW
61	SPACER
62	RETAINER
63	PINION YOKE SPRING
64	PINION GEAR ASSM'
65	PINION YOKE
66	CLUTCH SPRING
67	CLUTCH CAM
68	CAM PLATE
69	PLATE SCREW
70	CLUTCH LEVER
71	CLUTCH LEVER SCREW
72	CAST CONTROL SPRING
73	WASHER
74	CAST CONTROL CAP
75	PROTECTOR-R
76	PROTECTOR-R SCREW
77	RIGHT COVER SCREW
78	SPRING WASHER
80	STAR DRAG
81	LEAF SPRING
82	HANDLE ASSM'
83	HANDLE NUT
84	NUT RETAINER
85	NUT RETAINER SCREW
86	CLUTCH SLEEVE

1146825
1145281
1146745
1146769
1145871