

# MotorGuide® REPAIR PARTS

**Model:**  
**767P**

**SPECIFICATIONS:**

Year of Intro 2001  
 Thrust 67LBS  
 Volts 12/24VDC  
 Amp Draw ~ 0 to 34amps  
 Stnd. Mount 21 Gator II  
 Speeds 5 speeds

**PARTS ORDERING & TECH ASSISTANCE**

Consumer Relations  
 Phone 800-841-2738  
 Fax 800-982-8093

**RETURNING GOODS**

*Returned Goods must be accompanied with a Returned Goods Authorization. Contact MotorGuide Consumer Relations to obtain RGA.*

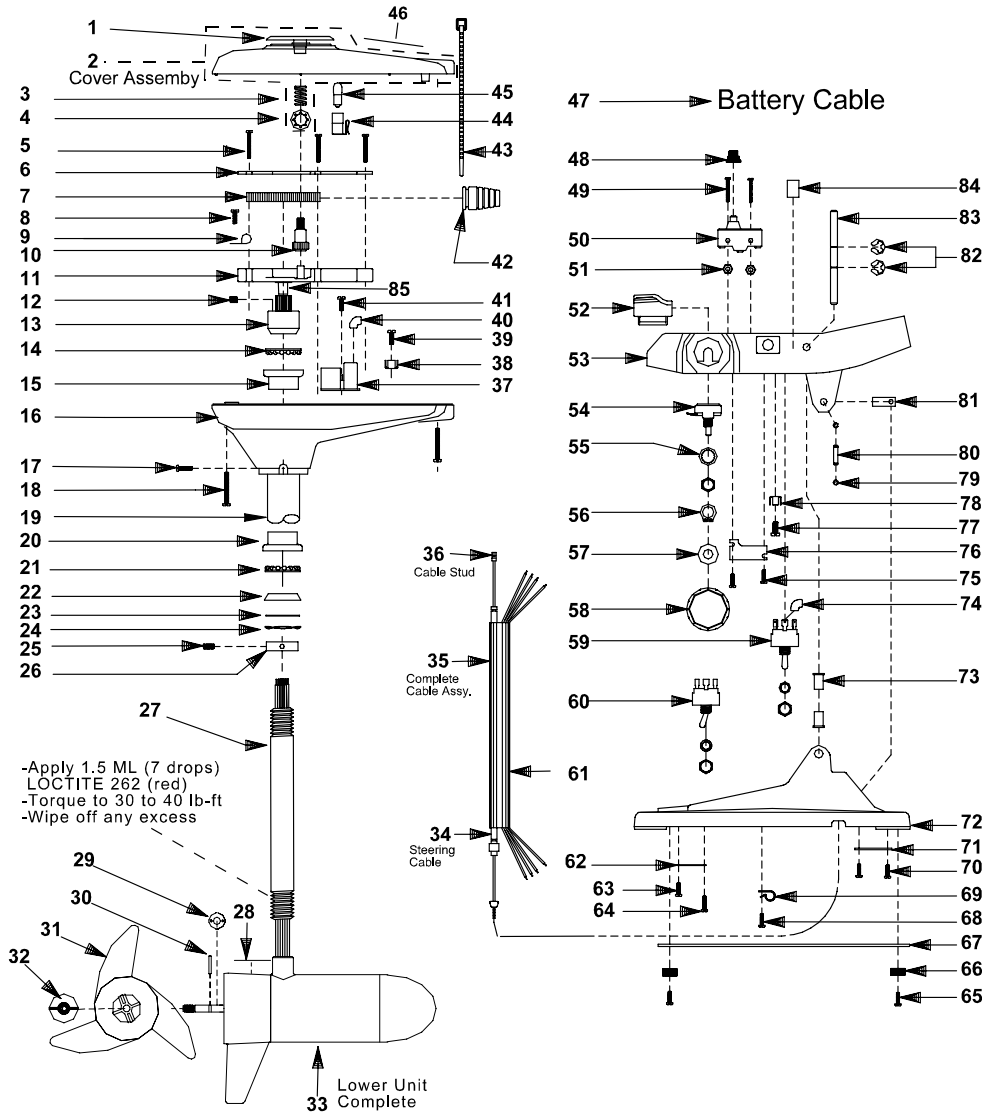

KEY	DESCRIPTION	PART #	KEY	DESCRIPTION	PART #	KEY	DESCRIPTION	PART #
1	RED INDICATOR	AF078-08	28	LOWER UNIT DECAL	AF060-07	56	GRIP RING	LP046-01
2	T/H COVER COMPLETE BLACK	AF053-13	29	MONOFILAMENT WASHER	AR175-01	57	NYLON WASHER	AK171-02
3	T/H COVER COMPLETE WHITE	AF053-12	30	PROP DRIVE PIN	BR102-02	58	5 SPEED KNOB	LP082-07
4	COMPRESSION SPRING	AF014-01	31	PROP	AF124-12	59	TOGGLE SWITCH 3 POSITIONS	FP153-03
5	TINNERMAN CLIP	AF046-01	32	PROP NUT	AR099-01	60		
6	#6 RACK GUIDE SCREW	AF133-01	33	F/O MOTOR WR	VS397-01	61	69" ELECTRIC CABLE JACKET	MM9006-03
7	RACK GUIDE COVER	AF127-01	34	63" CONTROL CABLE STUD ASY	9377	62	63" ELECTRIC CABLE JACKET	MM9006-02
8	RACK	AP125-01	35	69" CONTROL CABLE STUD ASY	9767	63	CABLE PLATE	KP123-01
9	#10 x 1/2" SCREW	GR133-01	36	63" CONTROL CABLE ASY	LP327-43	64	#6 SELF TAP SCREW	EK135-01
10	CABLE CLAMP	AP036-01	37	69" CONTROL CABLE ASY	LP327-44	65	6 X 1/2 SCREW	AF135-01
11	INDICATOR GEAR	AF069-01	38	CONTROL CABLE STUD	AP141-01	66	6 X 1/2 SCREW	AF135-01
12	RACK GUIDE	AF126-01	39			67	FOOT PEDAL PAD	KP023-01
13	1/4 NUT SET SCREW	AF142-01	40			68	WEIGHT PLATE ASY	LP3123-01
14	PM PINION NUT	AF398-01	41			69	6 X 1/2 SCREW	AF135-01
15	BEARING	FM005-01	42	GROMMET	AP071-01	70	6 X 1/2 SCREW	AF135-01
16	BEARING CUP	AF007-01	43	CABLE TIE	AF030-01	71	CABLE CLAMP	KP036-01
17	T/H BASE BLACK	AF004-07	44	LAMP HOLDER	AF394-01	72	SCREW	IR133-01
18	T/H BASE WHITE	AF004-06	45	LAMP	AF093-02	73	BATTERY CLAMP	KP036-02
19	#6 SELF TAP SCREW	EK135-01	46	NOMENCLATURE	BF056-17	74	FOOT PEDAL BASE	LP003-01
20	SCREW #8 X 3/4	LF141-03	47	BATTERY CABLE ASY	KP328-09	75	SHAFT BUSHING	KP021-01
21	42/50" OUTER TUBE	AF165-06	48	MICRO SWITCH BOOT	KP157-01	76	INSULATING SLEEVE	AT080-01
22	BEARING CUP	FM007-01	49	#6 32 X 1 1/2 SCREW	LP135-01	77	6 X 1/2 SCREW	AF135-01
23	BEARING	FM005-01	50	MICRO SWITCH	AP151-01	78	RETAINER PLATE	LP123-03
24			51	6 - 32 NUT S.S	SP098-02	79	#10X1/2 SCREW	GR133-01
25	CONE SET SCREW	AF143-01	52	MICRO BUTTON	LP026-01	80	ON SERT PAL NUT	TT098-03
26	BEARING CONE	AF006-01	53	FOOT PEDAL HI MARINE	LP101-03	81	E RING	FP046-01
27	42" .105 SS F/O COLUMN	AF049-09	54	ROTARY SWITCH	HF150-01	82	CABLE PIVOT PIN	AP105-01
	45" .105 SS F/O COLUMN	AF049-12	55	LOCK WASHER 3/8	KP171-01	83	CABLE PIVOT	LP091-01
						84	.312 E RING	BK046-02
						85	FOOT PEDAL ROCKER PIN	LP102-01
							12/24 DECAL	LP057-04
							PINION NUT BUSHING	AF021-01

# LOWER UNIT BREAKDOWN

Model:  
**767P**

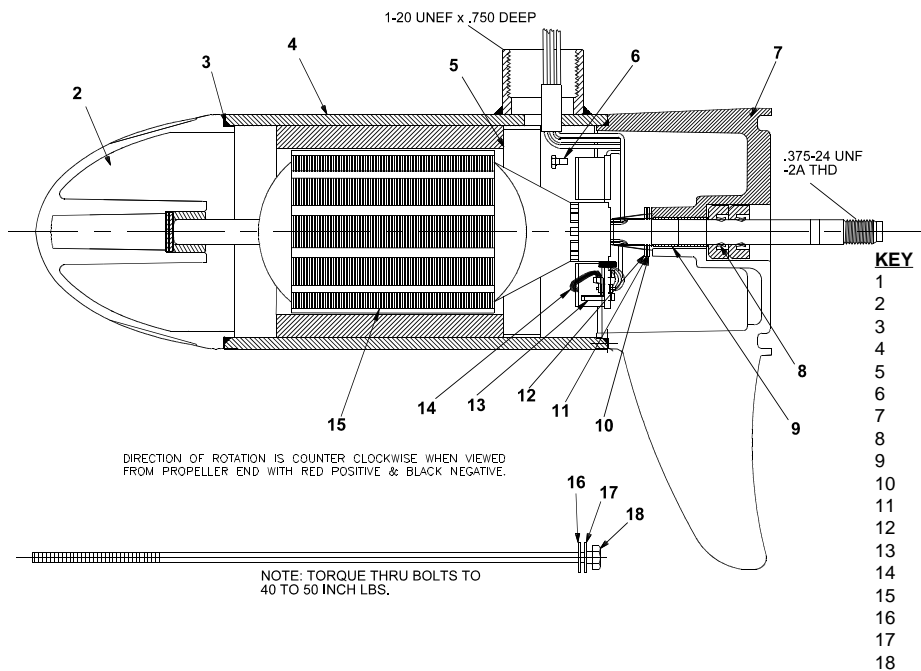

KEY	QTY	DESCRIPTION	PART NO.
1	X	MOTOR	VS397-01
2	1	NOSE CAP	XF3212-01
3	2	O RING SEAL	MR217-01
4	1	HOUSING ASY	US3210-03
5	1	RETAINER	JF233-01
6	2	BRUSH CARD SCREW	MR228-01
7	1	COMM CAP	VF3205-01
8	2	SHAFT SEAL	MR223-01
9	1	BEARING	MR206-01
10	1	NYLATRON WASHER	MR226-01
11	1	WASHER	MR227-01
12	1	E RING	MR219-02
13	2	BRUSH SPRINGS	MR214-02
14	1	BRUSH ASY LESS SPRING	VF3205-01
15	1	ARMATURE	UF3207-01
16	4	STATIC SEAL	MR222-01
17	4	THRU BOLT WASHER	MR216-01
18	2	THRU BOLT	MR218-02

## WIRING

