

50PD  
50 LBS THRUST  
12 VOLT  
54" OR 48" SHAFT

For parts and service  
call toll free: 1-888-404-1119  
www.mikesreelrepair.com

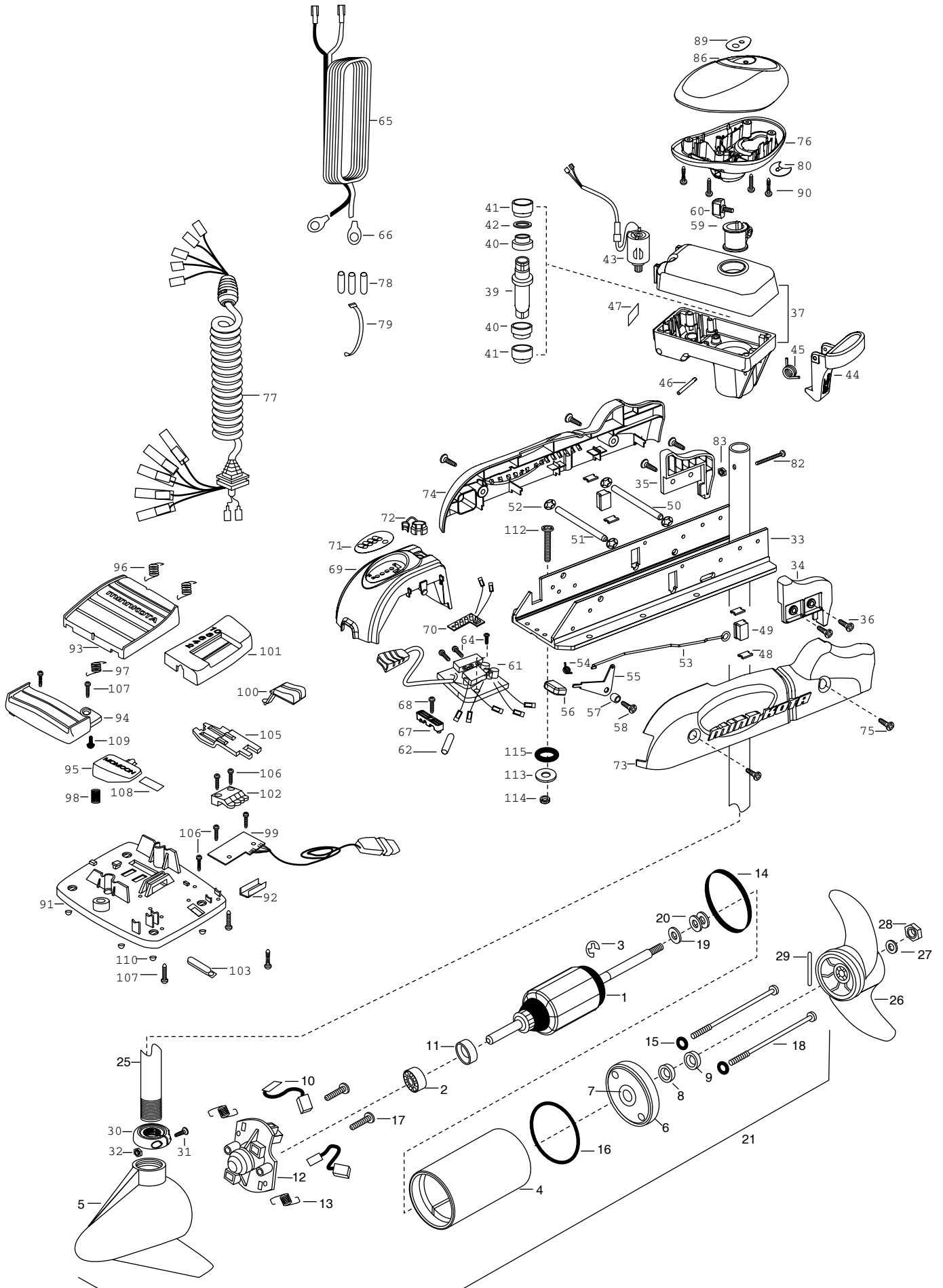

For parts and service  
call toll free: 1-888-404-1119  
www.mikesreelrepair.com

1	92-100-098	ARMATURE ASSEMBLY 12V 3.62	■	2882011	BUSHING/ OUTSHAFT KIT	75	2303430	SCREW-1/4-20 X 5/8- [4.EA]
2	140-010	BALL BEARING			(INCLUDES 39-42)	76	2302515	CONTROL BOX PD/AP
3	788-015	RETAINING RING	*39	2302010	DRIVE HOUSING OUTPUT SHAFT	77	2991251	COIL CORD WSTRAIN RELIEF 54"
4	2-200-101	HOUSING ASSEMBLY CENTER 3.62 TXT	*40	2307304	BUSHING- INNER [2.EA]		2991250	COIL CORD WSTRAIN RELIEF 48"
5	421-065	HOUSING BRUSH END 3.62 TXT	*41	2307305	BUSHING- OUTER [2.EA]	78	2065400	WIRE INSULATOR-LGE 1-3/4 [3.EA]
6	2-400-101	PLAIN END HOUSING ASSEMBLY 3.625	*42	2304603	O-RING [2.EA]	79	9950433	TIE WRAP-4" BLACK
7	144-049	BEARING - FLANGE (SERVICE ONLY)	43	2307045	MOTOR- DRIVE HOUSING HIGH SPD	80	2224700	INSERT- PLUG
8	880-003	**SEAL	44	2307205	LATCH HANDLE PD/AP	82	2033400	SCREW-10-24 X 1-3/4
9	880-006	**SEAL WITH SHIELD	45	2302750	SPRING- LATCH TORSION PD/AP	83	2013110	NUT-HEX 10-24 NYLOC
10	188-036	BRUSH ASSEMBLY [2.EA]	46	2302625	PIN- ROLL 3/16X2 ZINC PLATE	86	2300235	CONTROL BOX COVER- POWERDRIVE
11	725-050	BRUSH RETENTION- PAPER TUBE	47	2305514	DECAL-STOW/DEPLOY	89	2315665	DECAL- COVER 50PD '2001
12	738-036	BRUSH PLATE W/HOLDER	48	2305110	PAD-PIVOT SUPT [4.EA]	90	2012100	SCREW-8-18 X 5/8 [4.EA]
13	975-040	SPRING - TORSION [2.EA]	49	2305101	PIVOT PAD [2.EA]	■	2774700	FOOT PEDAL ASSEMBLY
14	337-036	**GASKET	50	2300500	PIN-LATCH	91	2304511	FOOT PEDAL BASE
15	701-008	**O-RING, THRU-BOLT [2.EA]	51	2300510	PIN-PIVOT	92	2308500	WEAR PLATE FOOT PDL
16	701-081	**O-RING	52	2013100	NUT-SPEED [4.EA]	93	2304516	FOOT PEDAL-UPPER
17	830-007	SCREW-8-32 [2.EA]	53	2303612	ROD-RELEASE RT/AP SS	94	2304520	FOOT PEDAL-LOWER
18	830-042	THRU-BOLT 10-32X8.83 [2.EA]	54	2302700	SPRING-RELEASE LEVER	95	2307210	LEVER MOM/CON-
19	990-067	WASHER- STEEL THRUST	55	2303710	LEVER-RELEASE	96	2302730	SPRING-LONG-UPPER PEDAL [2.EA]
20	990-070	WASHER - NYLATRON [2.EA]	56	2300101	RELEASE-KNOB	97	2302731	SPRING-SHORT-UPPER PEDAL
21	2099034	MOTOR ASSEMBLY 12V 3.62 VARS TXT	57	2301700	SPACER-RELEASE LEVER	98	2302732	SPRING-LOWER PEDAL
25	2032076	TUBE- COMPOSITE 54"	58	2303430	SCREW-1/4-20 X 5/8	99	2304012	CONTROL BOARD ASSEMBLY-FT PDL
	2032075	TUBE- COMPOSITE 48"	59	2031522	COLLAR- DRIVE (W/INSERT)	100	2300120	KNOB-SPEED SELECTOR
■	1378122	PROPELLER KIT	60	2011365	SCREW-COLLAR/NEW KNOB	101	2300121	HOUSING SPEED SELECTOR
26	2091150	PROPELLER W/WEDGE	61	2304041	CONTROL BOARD ASSEMBLY- 12V PD/AP	102	2302840	ACTUATOR-BOARD
27	2151726	WASHER-5/16 SS	62	2355410	SHRINK TUBE-3/8 ODX2	103	2302841	ACTUATOR-MOM/CON
28	2053101	NUT-PROP NYLOC	64	2332100	SCREW-8-32 X 3/8 [3.EA]	105	2302842	ACTUATOR-STEERING
29	2092600	PIN-DRIVE	65	2090601	LEADWIRE IOGA 44"	106	2302100	SCREW-6-20 X 1/2 [5.EA]
30	2301545	COLLAR- LATCH PD/AP	66	2020700	TERMINAL RING [2.EA]	107	2372100	SCREW-8-18 X 5/8 [5.EA]
31	2303434	SCREW- 8-32X5/8 MACH PHCR	67	2222906	STRAIN RELIEF- BRACKET PD/AP	108	2266610	DECAL-ON/OFF SWITCH
32	2303112	NUT 8-32 NYLOC SS	68	2303430	SCREW-1/4-20 X 5/8	109	2335130	BUMPER ACTUATOR
33	2301932	EXTRUSION- BASE MACHINED	69	2306555	HOUSING- CENTER PD/AP	110	2994807	BAG ASSEMBLY- 4 RUBBER BUMPERS
34	2303932	MOTOR REST- RIGHT LARGE	70	2034025	BATTERY GAUGE - 12 VOLT	■	2994803	BAG ASSEMBLY- (BOLT,NUT,WASHERS)
35	2303937	MOTOR REST- LEFT LARGE	71	2306609	DECAL, BATTERY GAUGE	*112	2153501	BOLT-MOUNTING-3500 W/STG [4.EA]
36	2303430	SCREW 1/4-20X5/8 SELF TAP [4.EA]	72	2302935	STRAIN RELIEF-DR. HOUSING	*113	2151726	WASHER-5/16 [4.EA]
37	2301845	DRIVE HOUSING PD/AP 2001	73	2303941	SIDEPLATE (RIGHT)PD	*114	2153100	NUT-5/16-18 MOUNTING [4.EA]
			74	2303946	SIDEPLATE(LEFT)PD	*115	2301720	WASHER-MOUNTING RUBBER [6.EA]

# 50PD Wiring Diagram

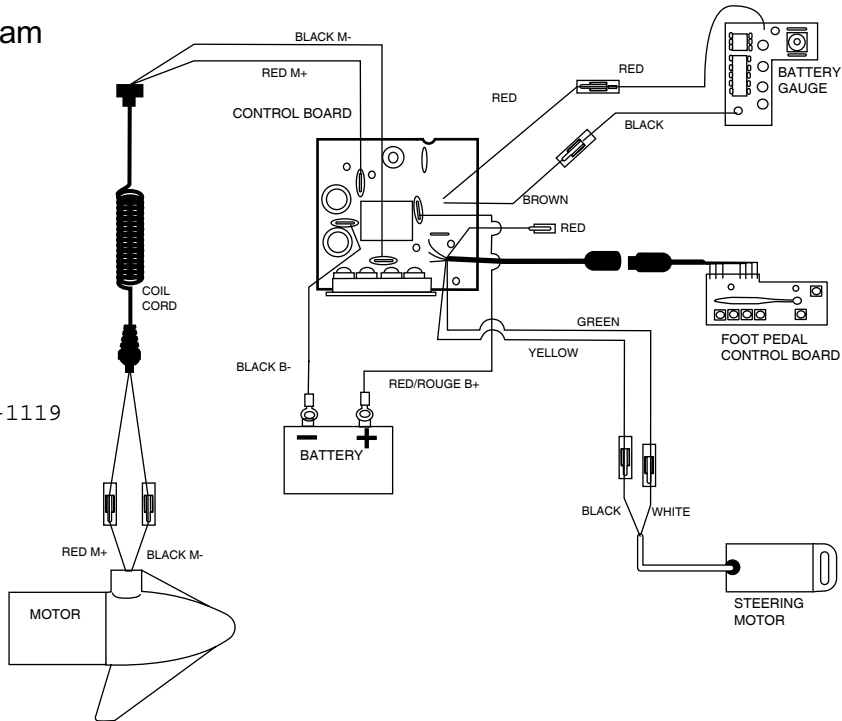

For parts and service

call toll free: 1-888-404-1119

[www.mikesreelrepair.com](http://www.mikesreelrepair.com)