

09 WIDEBITE BLACK
WITH QUIK STOW
COMPLETE ASSY: SK300-01

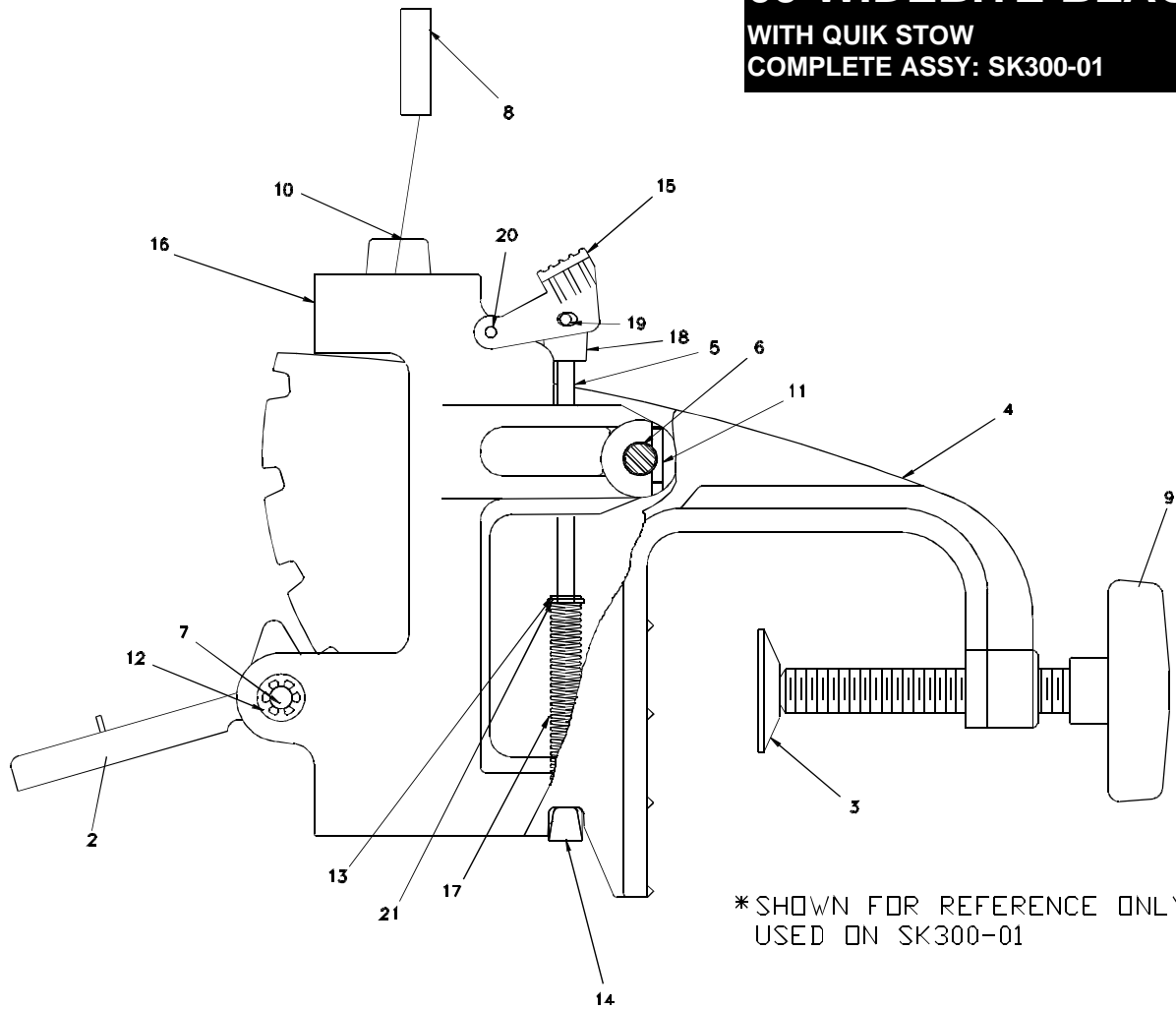

FEATURES

- Fits transoms up to 3" wide
- Heavy-duty extruded aluminum construction
- Convenient Quik Stow lever (Select models)
- Fast tilt mechanism

ENVIRONMENT

- Freshwater

STANDARD ON

- T Series 43 lbs thrust & up
- All Quik Stik models

1	21	WASHER	HK171-02
1	20	ROLL PIN	CB110-02
1	19	09 MT. TILT BUTTON PIN	CB110-02
1	18	09 MT. TILT BUTTON	SK023-01
1	17	SPRING	CK014-01
1	16	09 COLUMN SUPPORT H.O.	SK021-01
1	15	09 MT. TILT ACTUATOR	SK001-01
1	14	09 MT.LATCH BAR	SK024-01
1	13	E RING	AK046-01
2	12	1/4 RETAINING RING	AK046-03
1	11	ROLL PIN	SK101-01
1	10	BAR KNOB, TENSION	CK082-05
2	9	BAR KNOB, CLAMP	CK082-04
*	8	FRICTION STRIP	SK100-01
1	7	PIN QUICK STOW 09MT.	SK102-01
1	6	PIVOT PIN	SK105-01
1	5	09 MT.LATCH PIN	SK106-01
1	4	09 MT BRACKET	SK167-01
2	3	CLAMP WASHER	CK171-01
1	2	LOCKING ASSEMBLY	CB372-01
1	1	09 MOUNT Q.S. H.O.	SK300-01
NO. RECD	ITEM NO.	PART	PART NO.
MATERIAL:		STANDARD TOLERANCES UNLESS SPECIFIED	
SEE ABOVE		DECIMAL .XX +/- .010	
FINISH:		DECIMAL .XXX +/- .005	
		ANGULAR +/- 1°	
PART NAME		DRN BY <i>R</i> 5/14/96	
09 MOUNT-BLACK		CHK BY	
		APP BY	
		SCALE NONE	
MotorGuide		DWG. NO.	
ZEBCO/MOTORGUIDE P.O. BOX 4345 STARKVILLE, MISSISSIPPI 39759 ZEBCO CORPORATION, A BRUNSWICK CO.		SK192-01	